

USER MANUAL

SERIES 1260 VXI SWITCHING CARDS

PUBLICATION NO. 980673-999

RACAL INSTRUMENTS

Racal Instruments, Inc.

4 Goodyear St., Irvine, CA 92618-2002
Tel: (800) RACAL-ATE, (800) 722-2528, (949) 859-8999; FAX: (949) 859-7139

Racal Instruments, Ltd.

480 Bath Road, Slough, Berkshire, SL1 6BE, United Kingdom
Tel: +44 (0) 1628 604455; FAX: +44 (0) 1628 662017

Racal Systems Electronique S.A.

18 Avenue Dutartre, 78150 LeChesnay, France
Tel: +33 (1) 3923 2222; FAX: +33 (1) 3923 2225

Racal Systems Elettronica s.r.l.

Strada 2-Palazzo C4, 20090 Milanofiori Assago, Milan, Italy
Tel: +39 (0)2 5750 1796; FAX +39 (0)2 5750 1828

Racal Elektronik System GmbH.

Technologiepark Bergisch Gladbach, Friedrich-Ebert-Strasse, D-51429 Bergisch Gladbach, Germany
Tel.: +49 2204 8442 00; FAX: +49 2204 8442 19

Racal Instruments, Ltd.

Unit 5, 25F., Mega Trade Center, No 1, Mei Wan Road, Tsuen Wan, Hong Kong, PRC
Tel: +852 2405 5500, FAX: +852 2416 4335

<http://www.racalstruments.com>



PUBLICATION DATE: FEBRUARY 24, 2003

Copyright 2001 by Racal Instruments, Inc. Printed in the United States of America. All rights reserved.
This book or parts there of may not be reproduced in any form without written permission of the publisher.

Thank you for purchasing this Racal Instruments product.

For this product, or any other Racal Instruments product that incorporates software drivers, you may access our web site to verify and/or download the latest driver versions. The web address for driver downloads is:

<http://www.racalstruments.com/downloads>

You will be asked to register one time only to gain access to the driver and product manual downloads sections. At registration a cookie will be placed on your computer if you choose to accept it. This is done to facilitate your use of these sections on future visits. You may refuse to accept the cookie and still have complete access to the software driver database but will have to re-register every time you visit. This cookie is for ease of use only and no information is gathered for, sold, or reported to, any third party organization.

If you have any questions about software driver downloads or our privacy policy, please contact us at info@racalstruments.com.

WARRANTY STATEMENT

All Racal Instruments, Inc. products are designed and manufactured to exacting standards and in full conformance to Racal's ISO 9001 procedures.

This warranty does not apply to defects resulting from any modification(s) of any product or part without Racal's express written consent, or misuse of any product or part. The warranty also does not apply to fuses, software, non-rechargeable batteries, damage from battery leakage, or problems arising from normal wear, such as mechanical relay life, or failure to follow instructions.

This warranty is in lieu of all other warranties, expressed or implied, including any implied warranty of merchantability or fitness for a particular use. The remedies provided herein are buyer's sole and exclusive remedies.

For the specific terms of your standard warranty, or optional extended warranty or service agreement, contact your Racal customer service advisor. Please have the following information available to facilitate service.

1. Product serial number
2. Product model number
3. Your company and contact information

You may contact your customer service advisor by:

E-Mail:	Helpdesk@racalstruments.com	
Telephone:	+1 800 722 3262	(USA)
	+44(0) 8706 080134	(UK)
	+852 2405 5500	(Hong Kong)
Fax:	+1 949 859 7309	(USA)
	+44(0) 1628 662017	(UK)
	+852 2416 4335	(Hong Kong)

RETURN of PRODUCT

Authorization is required from Racal Instruments before you send us your product for service or calibration. Call your nearest Racal Instruments support facility. A list is located on the last page of this manual. If you are unsure where to call, contact Racal Instruments, Inc. Customer Support Department in Irvine, California, USA at 1-800-722-3262 or 1-949-859-8999 or via fax at 1-949-859-7139. We can be reached at: helpdesk@racalstruments.com.

PROPRIETARY NOTICE

This document and the technical data herein disclosed, are proprietary to Racal Instruments, and shall not, without express written permission of Racal Instruments, be used, in whole or in part to solicit quotations from a competitive source or used for manufacture by anyone other than Racal Instruments. The information herein has been developed at private expense, and may only be used for operation and maintenance reference purposes or for purposes of engineering evaluation and incorporation into technical specifications and other documents which specify procurement of products from Racal Instruments.

DISCLAIMER

Buyer acknowledges and agrees that it is responsible for the operation of the goods purchased and should ensure that they are used properly and in accordance with this handbook and any other instructions provided by Seller. RII products are not specifically designed, manufactured or intended to be used as parts, assemblies or components in planning, construction, maintenance or operation of a nuclear facility, or in life support or safety critical applications in which the failure of the RII product could create a situation where personal injury or death could occur. Should Buyer purchase RII product for such unintended application, Buyer shall indemnify and hold RII, its officers, employees, subsidiaries, affiliates and distributors harmless against all claims arising out of a claim for personal injury or death associated with such unintended use.

FOR YOUR SAFETY

Before undertaking any troubleshooting, maintenance or exploratory procedure, read carefully the **WARNINGS** and **CAUTION** notices.

This equipment contains voltage hazardous to human life and safety, and is capable of inflicting personal injury.

If this instrument is to be powered from the AC line (mains) through an autotransformer, ensure the common connector is connected to the neutral (earth pole) of the power supply.

Before operating the unit, ensure the conductor (green wire) is connected to the ground (earth) conductor of the power outlet. Do not use a two-conductor extension cord or a three-prong/two-prong adapter. This will defeat the protective feature of the third conductor in the power cord.

Maintenance and calibration procedures sometimes call for operation of the unit with power applied and protective covers removed. Read the procedures and heed warnings to avoid “live” circuit points.

Before operating this instrument:

1. Ensure the instrument is configured to operate on the voltage at the power source. See Installation Section.
2. Ensure the proper fuse is in place for the power source to operate.
3. Ensure all other devices connected to or in proximity to this instrument are properly grounded or connected to the protective third-wire earth ground.

If the instrument:

- fails to operate satisfactorily
- shows visible damage
- has been stored under unfavorable conditions
- has sustained stress

Do not operate until performance is checked by qualified personnel.

Racal Instruments

EC Declaration of Conformity

We

Racal Instruments Inc.
4 Goodyear Street
Irvine, CA 92718

declare under sole responsibility that the

Opt-01 1260-Series Smart Control Module, P/N 401901-005

conforms to the following Product Specifications:

Safety: EN61010-1:1993+A2:1995

EMC: EN61326:1997+A1:1998

Supplementary Information:

The above specifications are met when the product is installed in a Racal Instruments certified mainframe with faceplates installed over all unused slots, as applicable

The product herewith complies with the requirements of the Low Voltage Directive 73/23/EEC and the EMC Directive 89/336/EEC (modified by 93/68/EEC).

Irvine, CA, May 9, 2002

Engineering Director

This page was left intentionally blank.

Table of Contents

Chapter 1	
GENERAL INFORMATION	1-1
Introduction	1-1
General Information.....	1-1
Options.....	1-3
Option 01	1-3
Chapter 2	
INSTALLATION INSTRUCTIONS.....	2-1
Introduction	2-1
Unpacking and Inspection	2-1
Reshipment Instructions	2-1
Option 01 Installation.....	2-1
Interrupt Level and Logical Address Setting (1260-01 - Equipped Modules Only)	2-4
Switching Module Address Setting (All Modules)	2-5
Local Bus Daisy chaining	2-6
LBUS Lockout Keys	2-7
Switching Module Chassis Installation	2-9
Chapter 3	
OPERATION.....	3-1
Introduction	3-1
Input Format.....	3-1
Output Format	3-1
1260-01 Device Dependant Command Codes	3-3
CLOSE.....	3-3
CNF.....	3-3
DLY	3-3
EOI.....	3-4
EQU	3-5
EXCL.....	3-6
OPEN.....	3-6
PDATAOUT.....	3-8
PSETUP.....	3-10
PUPRCL.....	3-11
READ	3-11
RECALL	3-11

RESET	3-11
SCAN	3-12
SETUP	3-12
SLIST	3-13
SRQMASK	3-14
STORE	3-15
SYNC	3-16
TEST	3-16
TTLTRG	3-17
YERR	3-17
Chapter 4	
THEORY OF OPERATION	4-1
Introduction	4-1
Functional Blocks	4-1
Theory of Operation	4-3
Power Suppliers	4-3
Microprocessor Block	4-3
The Reset Circuits	4-4
VXI Interface	4-5
The Lbus Interface	4-6
Chapter 5	
DRAWINGS	5-1
Chapter 6	
PARTS LISTS	6-1
Chapter 7	
Product Support	7-1
Reshipment Instructions	7-1
Support Offices	7-2

List of Figures

Figure 1-1, 1260 Series Switch Module..... 1-1
Figure 1-2, 1260 Series Smart Card and Slaves 1-2

Figure 2-1, 1260-01 Smart Card 2-2
Figure 2-2, Switching Module Connector and Switch Location 2-2
Figure 2-3, 1260-40 Switch, Connector and Jumper Location 2-3
Figure 2-4, S1 Switch Function 2-5
Figure 2-5, 1260 Series Master and Slave LBUS Interconnections 2-6
Figure 2-6 LBUS Lockout Keys 2-7
Figure 2-7, 1260 Series Master/Slave Configuration 2-8

Table 3-1, 1260 Option 01 Status Byte 3-15
Table 3-2, 1260 Series Error Codes..... 3-17

Figure 4-1, 1260 Smart Card Block Diagram..... 4-2
Figure 4-2, 1260 Microprocessor Block Diagram..... 4-2

GENERAL INFORMATION

Introduction

This manual provides the information necessary to install one or more of the Racal Instruments 1260 Series switching modules in a VXIbus compatible chassis, and to operate the switching modules correctly.

General Information

The 1260 switching modules are a range of C size, VXIbus compatible switching modules that provide switching for microwave, RF, audio, high voltage, high current, low level and video applications. The modules are configured as matrices, multiplexers, switching trees, SPDTs and DPDTs. Refer to Figure 1-1 which shows a 1260 Switch Module in a VXIbus chassis.

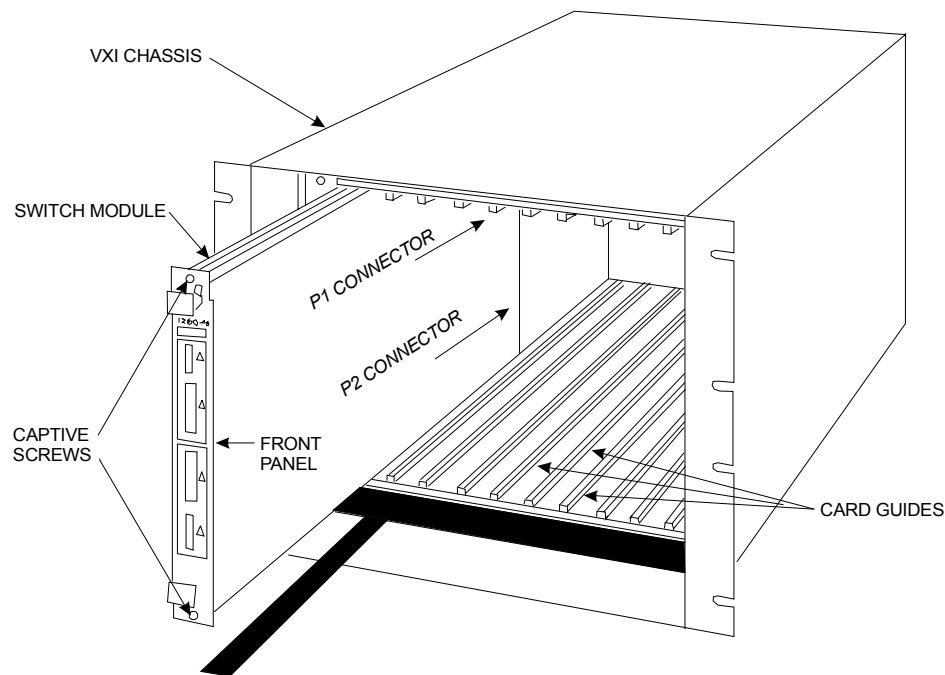

Figure 1-1, 1260 Series Switch Module

The switching modules are installed in a VXIbus compatible chassis in a continuous set of adjacent chassis slots. One of the modules to be fitted to the chassis must be designated the system Master, and must be fitted with Option 01. All other modules are slaved to the master. Refer to Figure 1-2 which shows the smart card and slaves.

The module fitted with Option 01 must be fitted in the leftmost chassis slot that is to contain a switching module. If only one module is to be fitted to the chassis, several jumper wires must be removed from, or DIP switches opened on, the switching module. If more than one module is to be fitted to the chassis, these jumpers must be removed from (or the DIP switches opened) the module in the rightmost chassis position containing a switching module.

NOTE

If you are using seven or more 1260 series modules, you must add a termination jumper to the module on the far right See Chapter 2.

Two separate addresses are required in the use of a 1260 switching system. The first is the VXIbus specification defined logical address used by the chassis Resource Manager and the second, the card address, is an address used by the 1260 Master to control the cards slaved to it. The card address is used in the device dependant commands used to control the switching modules. The logical address is set by a DIP switch on the 1260-01 Smart Card, and the card addresses are set by a DIP switch on the switching module PCB.

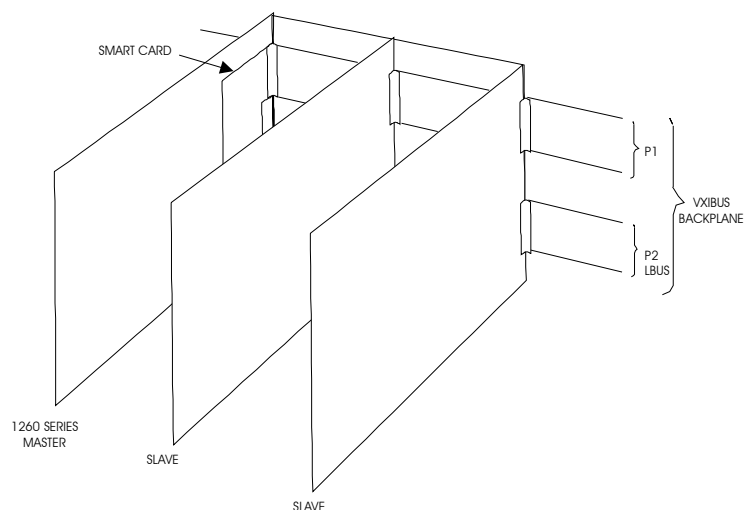

Figure 1-2, 1260 Series Smart Card and Slaves

Options

Option 01

The Option 01 Smart Card (Master) is required for use in all 1260 switching systems. This option acts as the switching system master, and all other switching modules are slaved to it. It turns any number of modules into a message-based VXIbus switching system.

The smart card is addressed over the VXIbus, and all other modules resident in the VXIbus chassis are controlled by this card. Option 01 uses the local bus on the VXI P2 connector to provide scanning, delay and exclude capabilities.

The built-in-test features in the smart card include confidence checking which monitors the state of each relay. It monitors a spare set of contacts or sensing coil current to ensure the switching system configuration is as programmed.

Refer to Section 2 for software installation procedures for the 1260-01, and to Section 3 for the software command set used to control the switching modules. The sections on individual modules describe the device specific installation and programming for each module.

This page was left intentionally blank.

INSTALLATION INSTRUCTIONS

Introduction

This section describes the unpacking and inspection, reshipment, installation and environmental requirements of the 1260 Series switching modules.

Unpacking and Inspection

Prior to unpacking the switching module, check the exterior of the shipping carton for any signs of damage. All irregularities should be noted on the shipping bill. Remove the instrument from the carton, preserving the factory packaging as much as possible. Inspect the switching module for any defect or damage. Immediately notify the carrier if any damage is apparent. Before use, have qualified personnel perform a safety check.

Reshipment Instructions

Use the original packaging when returning the switching module to Racal Instruments for calibration or servicing. The shipping carton and packaging will provide the necessary support for safe reshipment. If the original packaging is unavailable, wrap the switching module in plastic sheeting and use plastic spray foam to surround and protect the instrument. Reship in the original or a new shipping carton.

Option 01 Installation

To install Option 01 to a 1260 switching module, carry out the following procedure.

Remove the module top and bottom covers.

Remove the jumper board (Racal Instruments P/N 401951) fitted to connector J4 on the switching module. Note the 1260-40 has jumpers installed in the J4 connector that must be removed.

Remove the jumper board (Racal Instruments P/N 401951-003) fitted to connector J3 on the switching module.

Align the 1260-01 card with the switching module, P3 to J3, P4 to J4, and press the 1260-01 and the module firmly together to mate

the P3 and P4 connectors, taking care not to bend or damage any pins on the mating connectors. Refer to Figures 2-2 and 2-3 for the location of J3 and J4. Secure the 1260-01 card to the module with the fasteners provided at the three standoff positions on the 1260-01.

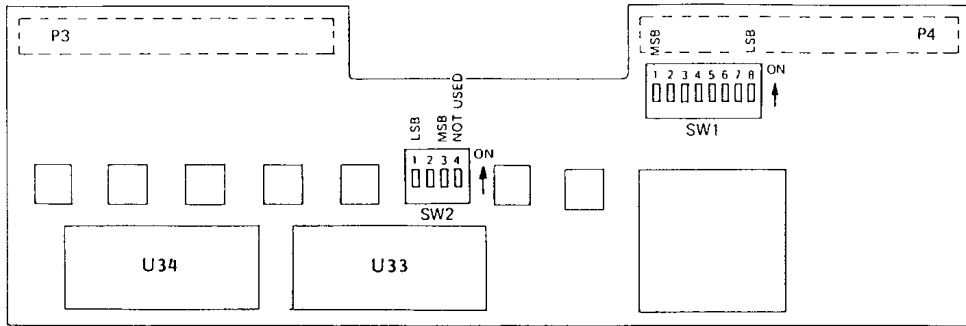

Figure 2-1, 1260-01 Smart Card

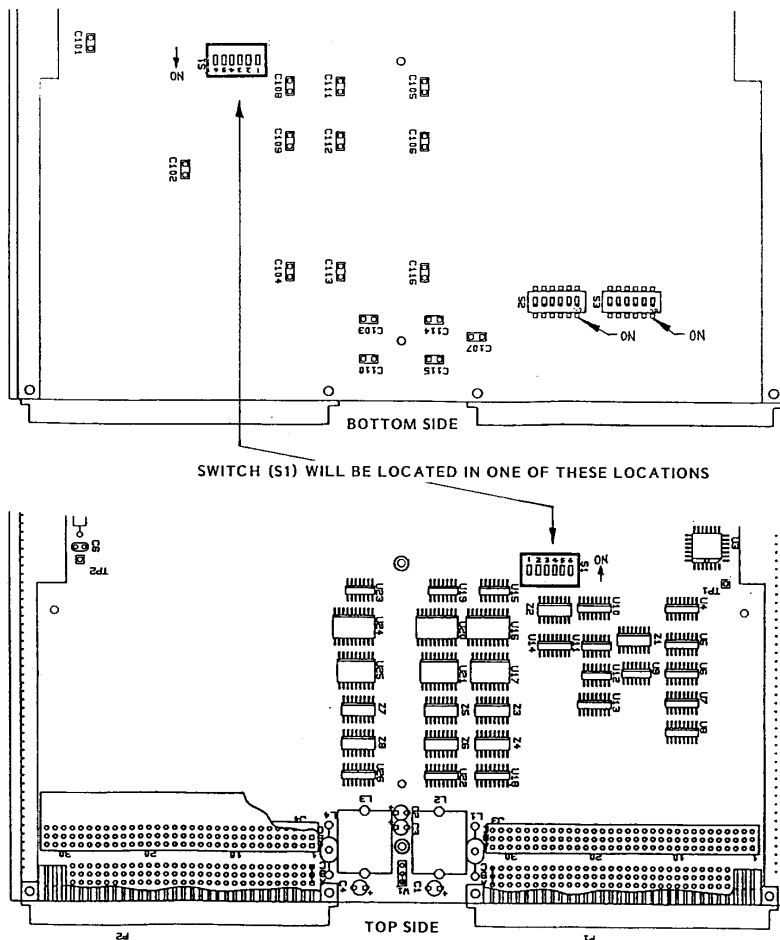

Figure 2-2, Switching Module Connector and Switch Location

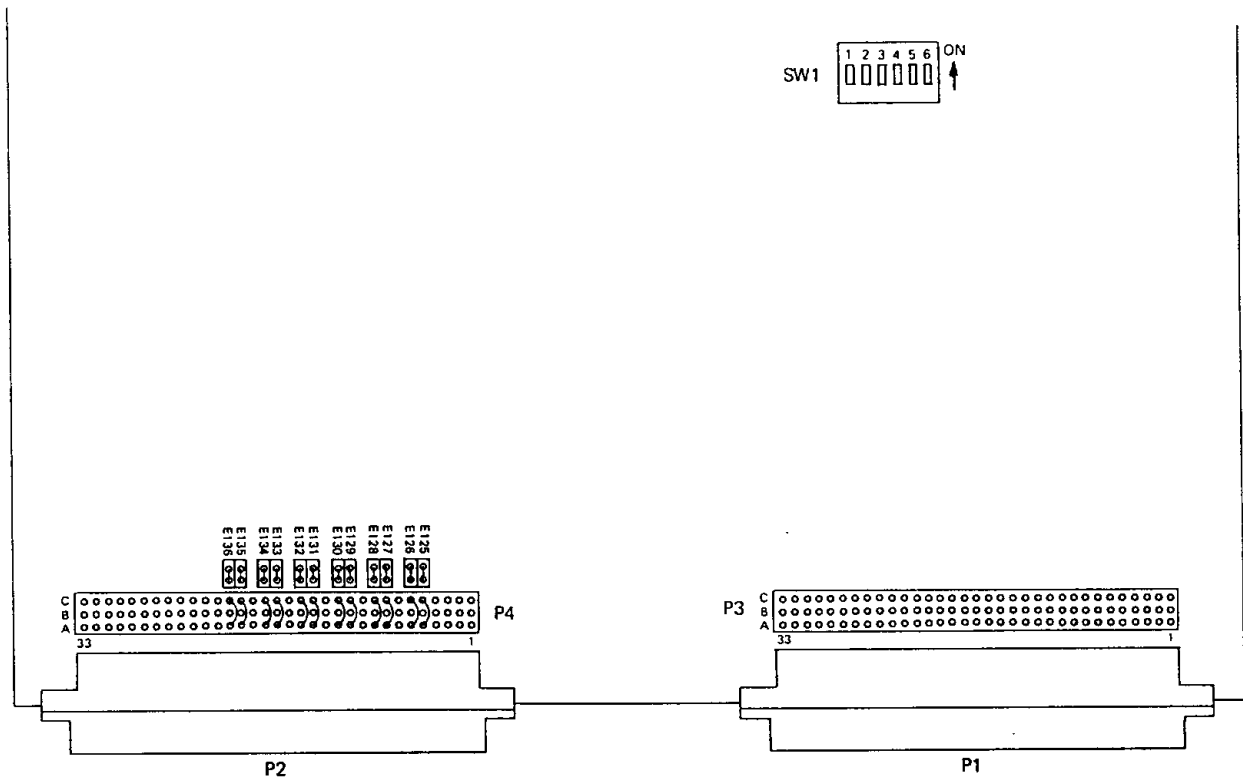

Figure 2-3, 1260-40 Switch, Connector and Jumper Location

The 1260 Master is fitted with the VXibus defined SYSFAIL LED. To install the LED, connect the cable supplied to the 3-pin plug in the Option 01 PCB. The cable and plug are configured to achieve correct operation either way the cable is connected at the end. The LED is inserted into the hole marked FAIL at the top of the module front panel from the outside of the module so the LED pins point into the module. The cable supplied is fitted with a 2-pin connector at the LED end, and is polarized to ensure correct installation.

Proceed to Subsection 2.5 to set the interrupt level and logical address of the Option 01.

**Interrupt Level
and Logical
Address Setting
(1260-01 -
Equipped
Modules Only)**

If not previously done, remove the module's top cover. To set the 1260-01 logical address, set switch SW1 on the 1260-01 board to the binary equivalent of the logical address selected. For SW1, a switch in the OFF position corresponds to binary 1, and the ON position corresponds to binary 0. Switch 1 on SW1 corresponds to the most significant digit, and switch 8 corresponds to the least significant digit. Logical addresses in the range 0 to 255 are permitted. Refer to Figure 2-1 for the location of SW1.

NOTE

The 1260-01 logical address is set to 15 by Racal Instruments before shipment.

All switching modules resident in a VXIbus chassis must have unique addresses. Incorrect operation of the system will result if two or more modules are set to the same module address.

To set the 1260-01 interrupt level, set switches 1, 2 and 3 on SW2 on the 1260-01 board to the binary equivalent of the interrupt level selected. For SW2, a switch in the OFF position corresponds to binary 1, and the ON position corresponds to binary 0. Switch 1 on SW2 corresponds to the least significant bit, and switch 3 corresponds to the most significant bit. Interrupt levels in the range 0 to 7 are permitted. Switch 4 is not used. Refer to Figure 2-1 for the location of SW2.

NOTE

The 1260-01 interrupt level is set to 2 by Racal Instruments before shipment.

Replace the module covers. Replacement is the reverse of the removal procedure.

NOTE

Any 1260 switching card may have Option 01 fitted and be designated as the Master.

Switching Module Address Setting (All Modules)

To set a module address, carry out the following procedure.

For the 1260-40 only, remove the module covers.

Set switch SW1 on the module to the binary equivalent of the address. Switches 1 to 4 are used to set the module address, with switch 4 the least significant bit, and switch 1 the most significant. The OFF positions for SW1 correspond to binary 0, and ON positions correspond to binary 1. Addresses in the range 1 to 12 are permitted. Refer to Figure 2-2 for the location of SW1 on the switching module PCB, or to Figure 2-3 for the location of SW1 on the 1260-40. The functions of the various S1 switches are shown in Figure 2-4.

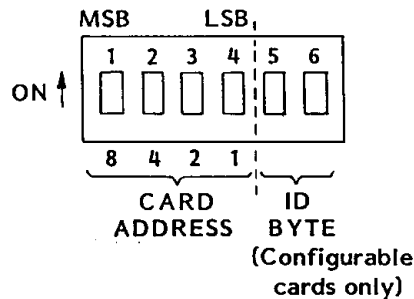

Figure 2-4, S1 Switch Function

NOTE

The address set at switch SW1 on the switching module controls the value of the card address the switching module will respond to. The OPEN and CLOSE statements using the card address are specified in Section 4.4. Example: For a module to respond to the command CLOSE 5.1205, the address of the module must be set to 5.

Several modules are capable of more than one configuration, and respond to different command codes in their various configurations. Switches 5 and 6 on SW1 are used to select the command code sets these modules respond to. Refer to the module specific sections for the procedure to set the switches for each module.

For the 1260-40 only, replace the switching module covers. Replacement is the reverse of the removal procedure.

Local Bus Daisy chaining

All modules slaved to a master must be daisy chained together along the VXI Local bus to allow communication between the Master and its Slaves. The modules must also be isolated from the rest of the VXI modules on the local bus. The daisy chaining of the Master and Slaves is implemented by the LBus Jumper PCBA (Racal Instruments P/N 405951) fitted to connector J4 on the modules and closing the S2 and S3 switches fitted to the underside of the module. The jumper board connects the local bus to the module from the left, and the switches connect the module to the local bus on the right of the module. The module fitted to the rightmost slot used must have all switches open to isolate the 1260 group from the rest of the VXI modules using the local bus. Note the 1260-40 has jumpers in positions E126 - E136 instead of DIP switches. Refer to Figure 2-5 which shows the LBus daisy chaining required by a 1260 Master and Slaves.

If you are using more than eight 1260 series modules, you must add a termination jumper to the module on the far right. Do this by soldering a short wire jumper across W22 on the LBUS jumper PCBA (P/N 401951, Rev. E).

Similarly, a provision must be made to pass the IACK and BUSGRANT 0-3 signals through Slave modules. This is done by installing the BUSGRANT Bypass PCBA (Racal Instruments P/N 401951-003) onto the modules' J3 connector. This PCBA is not required if the VXI chassis backplane contains jumpers or switches to bypass these signals and the switches are CLOSED

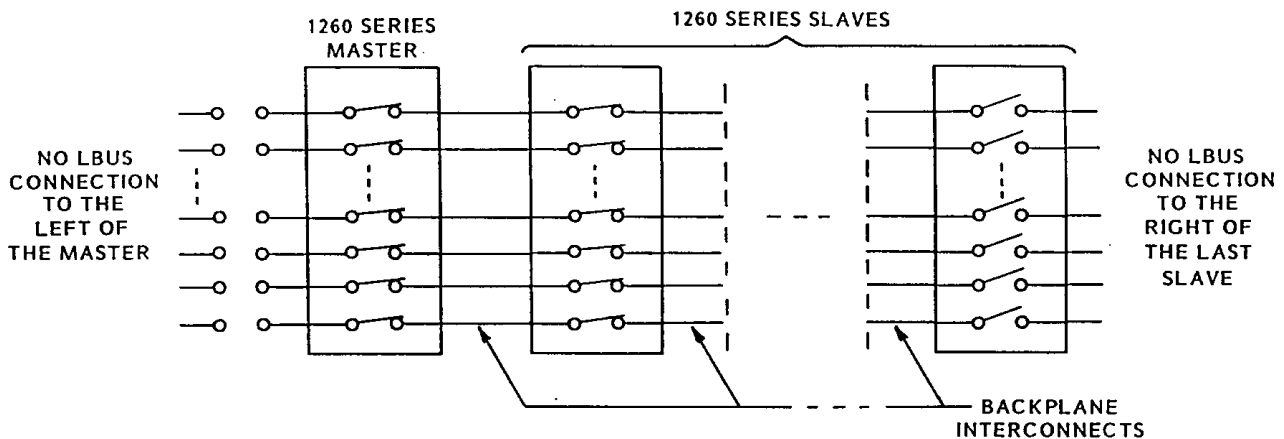

Figure 2-5, 1260 Series Master and Slave LBUS Interconnections

Revised 11/19/01

LBUS Lockout Keys

The VXibus defined LBUS lockout keys are designed to prevent the connection together of incompatible logic families. They are attached to the exterior of the module at the top of the front panel. Note: The 1260 Master must occupy the leftmost slot in the series. It is not required to occupy the leftmost slot in the chassis.

Note all modules shipped from the factory are supplied with three keys. Because their use is application dependent, it is the users responsibility to configure each module with the correct lockout key unless they are ordered specifying the modules that are to be the leftmost (Master) module, the rightmost module in the group, and the modules between the leftmost and rightmost modules.

Refer to Figure 2-6 which illustrates the three LBUS Lockout keys used, and to Figure 2-7 which shows a 1260 Master/Slave configuration.

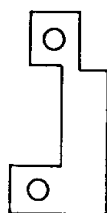

"C" Key

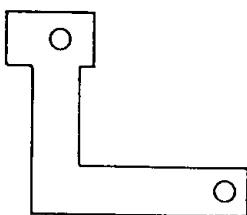

"A" Key

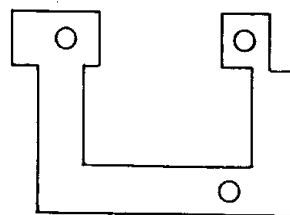

"A/C" Key

Figure 2-6 LBUS Lockout Keys

Racal Instruments implements the LBUS lockout scheme in one of three ways for each module as follows:

VXibus Defined "C" Key

The LBUS Lockout key (Racal Instruments P/N 455541) is fitted to the leftmost module in the group, i.e., the 1260 Master. It is connected to the LBUS to the right of the module, and the connection is TTL-compatible.

VXibus Defined "A" Key

The LBUS Lockout key (Racal Instruments P/N 455542) is fitted to the rightmost of the modules installed in a VXibus chassis. It is connected to the LBUS to the left of the module, and the connection is TTL-compatible.

VXibus Defined "A/C" Key

The BUS Lockout key (Racal Instruments P/N 455540) is fitted to all modules that are not the leftmost or the rightmost module in the group. The module is connected to the LBUS both to the left and to the right, and the connection is TTL-compatible.

A special case arises if only one module is to be installed in a VXIbus chassis. This configuration requires the Option 01 be installed, and the LBUS be open circuited to the right of the module. This will not require any use of the LBUS, and no LBUS Lockout keys are required.

Refer to Figure 2-6 which illustrates the three LBUS Lockout keys used, and to Figure 2-7 which shows a 1260 Master/Slave configuration.

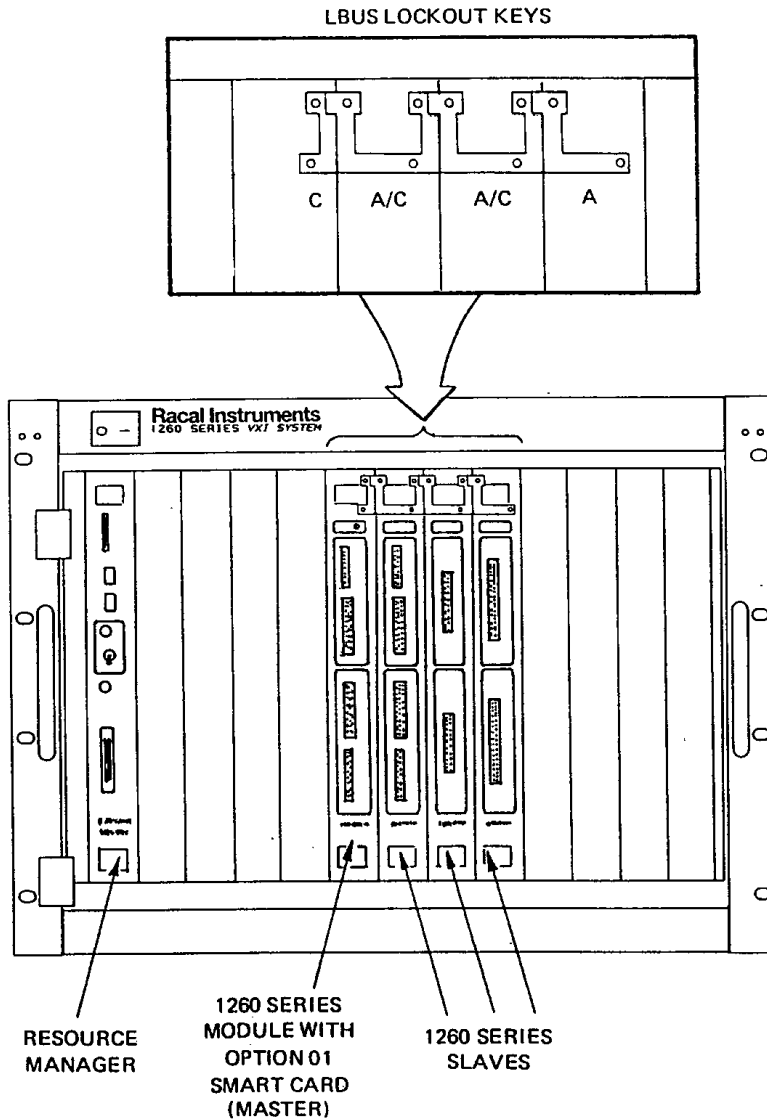

Figure 2-7, 1260 Series Master/Slave Configuration

LBUS Lockout Key Installation

In order to accommodate the VXIbus specification defined minimum thickness of the LBUS Lockout keys and the clearance provided around the module ejector handle, two LBUS Lockout keys must be fitted on top of each other to each module.

To install the A and C keys on a module, align the screw holes in the Lockout keys with the appropriate holes in the module front panel. Fit the two screws required, and secure the Lockout keys to the module front panel.

To install A/C Lockout keys to the module, the module ejector handle must be in the unejected position. The first key may be pushed around the ejector handle and aligned with the front panel screw holes. This takes up most of the clearance under the ejector handle, preventing the second Lockout key from being installed. To provide the necessary clearance, move the first Lockout key away from the module body, and slide the second key underneath the first key and around the ejector handle.

To secure the A/C Lockout keys to the module, align the Lockout keys screw holes with the holes in the module front panel. Install two screws in the holes at the top of the module front panel and tighten the screws. Move the ejector handle to the ejected position, and install a third screw in the hole now made accessible.

Switching Module Chassis Installation

Before installation of the switching module, visually inspect it to ensure there are no bent, damaged or missing pins. Pay particular attention to connectors P1 and P2 on the rear of the module. Repair any damage to the module before proceeding.

Before installing the switching system Master, the VXIbus specification defined IACKIN/IACKOUT, daisychain connection for the chassis slot the Master will be resident in, must be open circuited. This is accomplished in the Racal-Dana Model 1261 or 1262 chassis by opening the switch fitted on the daisychain. (Note: In later revisions of the 1261 and 1262 chassis, open circuiting is accomplished automatically when a module is installed into the chassis. See the appropriate chassis manual for more information.) The switch used is the higher of the two switches on the lower switchbank to the left of the slot the Master is to be fitted to. Note that other vendors may choose to implement the daisychain with either switches or jumpers.

If more than one switching module is to be installed in the VXIbus chassis, the module with the 1260-01 card installed must be fitted at the leftmost position of all modules being installed in the chassis. The rightmost module must have the twelve jumpers

mounted on the jumper PCB (installed) removed from positions E125 to E136 on the switching module PCB, or all DIP switches S2 and S3 opened, as described in Chapter 2.

To install the switching module in a C size, VXI mainframe, ensure the module has rear connector P1 oriented to mate with the corresponding connector on the mainframe backplane. Align the module with the guides for the slot selected, and slide the module into the mainframe. Push the module home to connect it to the mainframe. Secure the module to the mainframe with the captive screws provided at the top and bottom edges of the module.

Power up the mainframe. Ensure the SYSFAIL LED on the Master switching module front panel lights and extinguishes after a few seconds to show the switching module has passed its power up self-test. The switching module is now ready for use.

To remove the switching module, release the captive screws that secure the module to the mainframe. Use the plastic levers provided on the top and bottom edges to eject the module. Pull the switching module along the guides provided and out of the mainframe.

Chapter 3

operation

Introduction

This Chapter supplies the information necessary to operate 1260 Series switching modules housed in a VXIbus chassis. It describes the command codes and module specific syntax needed to control the 1260 Option 01 and switching modules, and the formats for the character strings output by the switching modules.

Input Format

The Option 01 is capable of recognizing any of the device dependant commands given in this chapter from the first two characters of the command, with the exception of the READ, RESET and RECALL commands which may be recognized from the first three characters of the command. The Option 01 will interpret a command in the same way if a command string supplies the first two or three or more characters of the command string.

The Option 01 will respond to the following terminators:

- line feed

- carriage return, line feed

- carriage return, line feed with EOI asserted

- GPIB line EOI asserted (when used with a GPIB/VXI Resource Manager)

Output Format

The Option 01 switching module will output character strings in response to the PDATAOUT, PSETUP and YERR commands. These character strings consist of one or more lines of information that will be terminated by the carriage return, line feed pair with the GPIB EOI line asserted as determined by the EOI <0|1> command. This means the character string output by the Option 01 may be required to be read repeatedly until the final line of the output is read for PDATAOUT and PSETUP commands. The final character string output by the Option 01 is <module address>.END, where <module address> is the address of the last module to be described. The character string output in response to

the YERR command is a single line.

The character strings output in response to the PDATAOUT and PSETUP commands consist of multiple lines of the form:

<module address>.<header> or <module address>.<module specific syntax>

where <module address> is the address set on switch SW1 on the switching module PCB, value 1 through 12. The value of <module address> and the decimal equivalent of the binary value set on SW1 must be the same for the switching module to respond correctly to any device dependant commands addressed to it. Note that no two switching modules are permitted to have the same value of <module address> in a VXIbus chassis.

<header> describes the switching module type.

<module specific syntax> describes the closed relay paths of the present configuration of the switching modules, or the synchronous port data on the digital card.

NOTE

The PSETUP command returns information on the configuration of the 1260 Option 01. The Option 01 will return a value of 000 for <module address>. This does not correspond to the address of the VXI Resource Manager card resident in Slot 0 of the VXI chassis, or the Option 01 logical address.

When outputting a character string to the VXI Controller, the Option 01 will output a carriage return, line feed pair. If the Resource Manager is a VXI/GPIB interface, the Resource Manager will output a carriage return, line feed with GPIB EOI asserted. Note that in the case of the output string consisting of multiple lines, the EOI line may be asserted at the end of each line or at the end of the character string, as determined by the EOI <1|0> command.

**1260-01 Device
Dependant
Command Codes**

NOTE

For any command that causes relays to be operated (e.g., CLOSE, OPEN, or RESET), allow 40msec to 3msec per relay operated relay settling time or monitor the READY bit of the status byte waiting till the 1260 reports that it is ready.

CLOSE

CLOSE <module address>.<module specific syntax> [;<module address>.<module specific syntax>]....

This command causes one or more connections on a switching module to close. Any number of connections in more than one slot may be closed in one CLOSE statement if the <module address>.<module specific syntax> sections are concatenated using a semi-colon (;). Refer to the individual module sections for the <module specific syntax> to be used for each switching module.

CNF

CNF <ON|OFF>

This command turns the 1260 Confidence Test On or Off. The Confidence Test checks that the state of all relays is as programmed, and causes the Option 01 to assert the VXI Request True exception after each OPEN or CLOSE command is processed if an error is detected. A character string detailing the failure may be obtained from the 1260-01 in response to the YERR command. The character string the Confidence test causes the Option 01 to generate is <module address>.51. <module address> is a three digit number that is the address of the module slaved to the 1260-01. 51 is the error code associated with a Confidence Test failure. A GPIB/VXI Resource Manager will cause the assertion of the GPIB SRQ line in response to the Request True assertion. The default (power-up) state for the Confidence Test is OFF.

DLY

DLY <value>

Command is used to cause a delay between the last relay closure after a command string is processed, and the SYNC OUT pulse. <value> may be 0-655 ms, and is set to zero at power up.

EOI

EOI <0|1>

EOI 0 causes the GPIB EOI line to be asserted by the VXI Resource Manager at the end of each line of a multi-line data output by the Option 01 if a VXI/GPIB Resource Manager is in use. EOI 0 is the default (power-up) state.

EOI 1 causes the GPIB EOI line to be asserted by the VXI Resource Manager only at the last character of a data string output by the Option 01 if a VXI/GPIB Resource Manager is in use.

EQU

EQU <equate list>

This command causes any OPEN, CLOSE or TRIG/SCAN commands addressed to any switching module on the <equate list> to be carried out for all modules on the <equate list>. All modules on the list are required to be identical.

The <equate list> is made up of the slot numbers of the switching modules that are to be equated separated by a semi-colon (;). Continuous groups of modules may be entered onto the <equate list> by entering the first and last modules to appear on the list joined by a hyphen (-). More than one equate group may be set up in a single EQU statement by separating the equate groups with a comma (,).

Example: EQU 1;3-6,2;9-11

This command will equate slots 1, 3, 4, 5 and 6 as one equate group and slots 2, 9, 10 and 11 as another.

NOTE

All switching modules must be of the same type to be accepted in the same equate list or the Option 01 will generate an error.

NOTE

Use of the EQU command will overwrite all previously entered <equate list>s. An <equate list> of 0 may be used to clear all equate groups.

NOTE

When an <equate list> is entered, all switching modules on the list adopt the state of the first module to appear on the list.

EXCL

EXCL <exclude list>

This command causes the Option 01 to regard the channel closures specified in the <exclude list> as mutually exclusive. A channel is described in the <exclude list> by the slot number of a switching module and module specific syntax to describe the relay closures in a channel. Refer to the individual module sections for the module specific syntax of the various switching modules available. More than one <exclude list> may be specified in an EXCL statement by separating the Exclude groups with the letter E and a semi-colon (E;). Continuous groups of modules may be entered onto the <exclude list> by entering the first and last modules to appear on the list joined by a hyphen (-).

NOTE

Use of the EXCL command will overwrite all previously entered <exclude list>s. An <exclude list> of 0 may be used to clear all exclude groups.

OPEN

OPEN <module address>.<module specific syntax> [<module address>

.<module specific syntax>].....

This command causes one or more connections on a switching module to open. Any number of connections in more than one slot may be opened in one OPEN statement if the <module address>.<module specific syntax> sections are concatenated using a semi-colon (;). Refer to the individual module sections for the <module specific syntax> to be used for each switching module.

PDATAOUT

PDATAOUT <module address>;<module address>.....

This command causes the specified switching modules to output the present state of the relays contained in those modules. An example character string output by the Option 01 response to a "PDATAOUT 0-12" is given below.

```
000. Model 1260 Universal Switch Controller
000. OS Rev 1.2 1260
012 1260-40A 4 x 24 signal matrix
012. 0219
012.END
```

This example shows that a 1260 Controller with an operating system revision level of 1.2 is present at module address 000. There is also a 1260-40A module present at address 012, and row 2 of the switching matrix is connected to column 19.

NOTE

The module address for PDATAOUT and PSETUP commands may specify a range of module addresses by using the syntax <start module address>-<end module address>. The Option 01 will output data for all modules between the starting and ending module addresses that are installed in the 1260.

NOTE

The switching module configuration is described in the same format as is required by the OPEN and CLOSE commands.

NOTE

The address obtained for the 1260 Universal Switch Controller is not the address of the slot 0 Resource Manager or the logical address of the 1260-01. It is equivalent to the module address of a switching module, and is always 000.

NOTE

The character string output by the Option 01 is made up of multiple lines and contains carriage-return, line-feed pairs. These may terminate the output string, and so the PSETUP output string must be read repeatedly until all lines of the output have been read for all modules specified. The final line output by the

1260 Option 01 is <module address>.END where <module address> is the VXI chassis slot that the last 1260 module described is resident.

PSETUP

PSETUP <module address>[;<module address>]....

This command causes the Option 01 to output a character string describing the setup of the switching system Option 01 and switching modules. An example of a character string obtained in response to a "PSETUP 0-12" command is given below.

```
000. Model 1260 Universal Switch Controller
000. OS Rev 1.2 1260
000. CNF OFF
000. DLY 0
000. EOI 0
000. EQU
000. EXCL
000. SCAN ON
000. SLIST 0
000. SRQMASK 40
000. SYNC 8
000. TTLTRG 0
000. PUPRCL OFF
012. 1260-40A 4 x 24 Signal Matrix
012. BBM
012.END
```

NOTE

The character string output by the 1260 Option 01 is made up of multiple lines and contains carriage-return, line-feed pairs. These will terminate the output string. The PSETUP output string must be read repeatedly until all lines of the output have been read for all modules specified. The final line output by the Option 01 is <module address>.END where <module address> is the VXI chassis slot that the highest module address present in the VXI chassis.

NOTE

The module address for PDATAOUT and PSETUP commands may specify a range of module addresses by using the syntax <start module address>-<end module address>. The Option 01 will output data for all modules between the starting and ending module addresses that are installed in the 1260.

PUPRCL

PUPRCL <ON|OFF>

This command enables and disables the automatic recall of non-volatile memory location 1 at power up. The configuration in non-vol location 1 is stored by the use of the STORE command. Refer to the appropriate paragraph for details of the STORE command.

NOTE

If non-volatile location 1 is cleared and PUPRCL is ON, no recall will take place at power up.

READ

READ <module address>.<module specific syntax>

This command is supported by digital cards only. Refer to the individual module sections for a description of the syntax and functions performed.

RECALL

RECALL <non-vol location>

where <non-vol location> = 1|2|.....|50

This command will set all switching modules in the VXI chassis to the configuration stored in the non-volatile location specified. The physical location of the modules in the chassis slots is unimportant as long as the same type modules are at the same module addresses as when the switching system configuration was stored, and the rules governing module locations are observed. Note that an error will be generated if an attempt is made to RECALL a memory setting into a switching system configuration that differs from the configuration present when the memory setting was stored. An error will also be generated if an attempt is made to RECALL a memory setting from an empty location.

RESET

RESET

NOTE

A delay of at least 100 msec may be required after a RESET command before issuing the next command.

This command causes all switching modules to be set to their de-energized states.

SCAN

SCAN <ON|OFF|CONT>

The SCAN ON command enables the Option 01 to open and close the channels as specified in the scan list in turn. Each channel is closed on receipt of a trigger signal from one of the VXIbus TTLTRG lines or the VXIbus trigger command is received. The Option 01 will scan the channels until it reaches a break point or the SCAN OFF command is received. Refer to Section 3.4.16 for further information on the scan list.

The SCAN CONT command causes the Option 01 to resume scanning the channels on the scan list after pausing at a break point in the scan list. The Option 01 will continue to scan until it reaches a break point on the scan list, or it receives the SCAN OFF command.

SCAN OFF causes the 1260 Series to stop scanning. Scanning may only be resumed by the use of the SCAN ON command.

NOTE

The SCAN command may also be used to recall non-volatile memory settings in turn.

SETUP

SETUP <module address>.<seqmode>

This command is used to control the sequence in which switching modules relays are opened and closed. The sequence modes (<seqmode>s) are IMM (Immediate), BBM (Break-Before-Make) and MBB (Make-Before-Break).

The Immediate (IMM) sequence mode will cause the opening and closing of switching module channels as quickly as possible, and the sequence of opening and closing is indeterminate. Care must be taken to avoid damaging connections while the switching module is in a state of transition, i.e., short circuiting power supplies to ground, connecting high power outputs together, or applying excessive power to low impedance inputs.

The Break-Before-Make (BBM) sequence mode causes existing channel closures to be opened before new channel closures are made. BBM is the default (power up) state.

The Make-Before-Break (MBB) sequence mode causes new channel closures to be executed before existing channel closures are opened.

SLIST

SLIST <scan list>

where <scan list> is <module address>.<channel> [;<module address>.<channel>];....

This command enters the slot and channel information to be used in the scan list while in the SCAN mode.

NOTE

Non-volatile memory locations may be specified instead of a <module address>.<channel>. It should be noted that if a non-volatile location is used, all relays closed as a result will stay closed when the next scan entry is executed, unless the next scan entry is another non-volatile recall location. With the normal <module address>.<channel > entry, the current scan entry is opened before the next is closed.

The range of values of <module address> is from 1 to 12. Switching channels are closed if <channel> is a module specific statement. If a non-volatile memory setting is used, it must be an integer value between 1 and 50.

A break point in the scan list will cause the Option 01 to stop scanning after opening the previous channel. A break point in the scan list is defined as the character zero (0), delimited by semi-colons (;0;). Scanning is resumed only after receipt of the SCAN CONT or SCAN ON commands. SCAN CONT will cause the Option 01 to resume scanning from the scan list break point it was paused at and the SCAN ON command will cause the Option 01 to resume scanning from the beginning of the scan list.

If the Option 01 pauses at a scan list break point, bit 4 of the GPIB status byte, Scan list at break point, is asserted and SRQ asserted if the SRQMASK permits. Refer to Section 3.4.17 for further information on the SRQMASK command.

SRQMASK

SRQMASK <32|33.....254|255>

This command controls the circumstances under which the Option 01 will cause a VXI/GPIB Resource Manager to assert SRQ by masking the Option 01 status byte. The mask value, <integer> is the decimal equivalent of the binary eight bit byte ANDED with the GPIB status byte, i.e., if a bit in the mask is a logic 1, the assertion of the corresponding bit in the status byte will cause the Option 01 to assert SRQ. Refer to Table 3-1 for the bit assignments of the GPIB Status byte. SRQ is asserted by raising the VXI Request True exception to the VXI Resource Manager. Note the status byte also details the possible responses of the 1260-01 to a GPIB serial poll.

NOTE

Service Requested (bit 7) is cleared by a VXI Status Request command (or by sending a serial poll to a VXI/GPIB Resource Manager. This will also raise a VXI Request False exception which will cause a VXI/GPIB Resource Manager to de-assert SRQ.

NOTE

Programming Error (bit 6) is cleared when the YERR command is received.

NOTE

Scan List at Break Point (bit 4) is cleared when a SCAN ON, SCAN OFF or SCAN CONT command is received.

Table 3-1, 1260 Option 01 Status Byte

Bit Number	Description
1 (lsb)	Unused
2	Unused
3	Unused
4	Scan List At Break Point
5	Ready
6	Programming Error
7	Service Requested
8 (msb)	Unused

The Programming error bit cannot be masked, and so the range of values for valid SRQMASKs is 32 - 63, 96 - 127, 160 - 191 and 223 - 255.

The power up (default) value of the SRQMASK is 40, i.e., programming error or Scanlist at break point will cause SRQ to be asserted.

STORE

STORE <non-vol location> where <non-vol location> = 1|2|.....|50

This command will store the present state of all switching modules resident in the VXI chassis in the non-volatile memory location specified.

A STORED configuration must be recalled into the same module set as was stored. Any changes in module location will be disregarded as long as the same module types are at the same module addresses as were stored.

SYNC

SYNC <0|1|2|3|4|5|6|7|8>

The commands SYNC <0|1|2|3|4|5|6|7> connect the selected SYNC output to the corresponding TTLTRG line. SYNC 8 disconnects the SYNC output from the TTLTRG lines and is the default (power up) state.

TEST

TEST 0.<testnumber> where <testnumber>::=1|2|3

This command causes the Option 01 to carry out a self test. The possible tests are:

Non-Destructive RAM Test

EPROM Checksum Test

Non-Destructive Non-Volatile Memory Test

NOTE

IF non-vol memory initialization is required, use the TEST 0.3 command to accomplish the initialization. Non-vol initialization will only be accomplished in the event of a firmware revision change, or if corruption of the non-vol is detected. If these conditions have not occurred, the TEST 0.3 command will be executed without reinitializing the non-vol memory. If non-vol memory initialization is required, the contents of the non-vol are invalid and will be erased during initialization.

On commencing a test, the Ready bit of the status byte is reset until the test is completed.

If self-test passes, the 1260-01 will return a hexadecimal 7F. If it fails, an SRQ is generated, and the operator must send a YERR command to determine the actual error.

TTLTRG

TTLTRG <0|1|2|3|4|5|6|7|8>

Commands TTLTRG <0.....7> cause the connection of one of the eight TTLTRG lines to a selected switching card. TTLTRG 8 deselects the TTLTRG line selected.

WRITE <module address>.<module specific syntax>

This command is supported by 1260 digital cards only. Refer to the individual module sections for a description of the syntax and functions performed.

YERR

YERR

This command causes the master switching module in a system to transmit the location (<module address>) of the most recent error and a two digit number (<error number>) that describes the error. Refer to Table 3-2 for a listing of all possible values of <error number> and the corresponding error descriptions.

Table 3-2, 1260 Series Error Codes

<error number>	Error Description
0	No error
1	Invalid module number specified
2	Specified module not installed
3	Invalid channel number specified
4	Invalid port number specified
5	Command syntax error
6	Read value larger than expected
7	Function not supported by module
8	Expected line terminator not found
9	Valid command not found
20	Exclude list too long
21	Channel entered on exclude list twice
22	Module doesn't allow exclude function
23	Scan list too long
24	Module doesn't allow scan
25	Equate list too long
26	Module entered on scan list twice
27	Incompatible modules equated or digital modules invalid
31	SRQMASK invalid
40	Number invalid as a test number

41 *	RAM test failure
42 *	ROM test failure
43 *	Non-vol memory test failure
44 *	Incompatible operating system EPROMS, software revisions
45 *	Self-test CPU or related circuitry failure
46 *	Self-test 24 V supply failure
47 *	Self-test timer chip failure
48 *	Insufficient RAM for option module
49 *	Checksum error reading from option module EPROM
50 *	Option module EPROM incompatible with CPU EPROM
51	Failed confidence test
55	Error STOREing to non-vol memory
56	Error RECALLing from non-vol memory
57	Non-vol storage location number out of range
58	RECALLing from an empty non-vol location not allowed
59	Non-vol memory initialization required (See description of TEST command for instructions on how to accomplished initialization.)
60	INCLUDE list too long
61	Channel entered on INCLUDED list twice
62	INCLUDE feature not supported by this module
63	Maximum number of INCLUDE lists exceeded
64	All relays on INCLUDE list must be in same module
65	Cannot INCLUDE previously EXCLUDED relays and vice versa
70	Improper or missed handshake on digital I/O

Note: * Denotes a **fatal** error

This page was left intentionally blank.

Chapter 4

Theory of operation

Introduction

This section describes the theory of operation of a 1260 Series switching system as configured from a 1260-01 Smart Card, and a 1260 Series switching module. The 1260-40 switching module is used as an example, and the reference designators for that card are used in the circuit descriptions given in this section.

This section begins with a block diagram description of the switching system, and extends the description to a discussion of the circuit action that takes place in the 1260-01 and 1260-40 at the component level.

Functional Blocks

The 1260-01 Switch Controller board consists of the following functional blocks:

- a. The Microprocessor Block
- b. The VXIbus Interface Block
- c. The Lbus Interface Block

The functional relationships between the blocks of the 1260-01 is illustrated in Figure 4-1. Switch configuration information is received from the VXIbus via the VXIbus interface, and routed to the microprocessor block. The commands received are interpreted by the microprocessor block, and the corresponding switch control information is transmitted to the appropriate switch module via the Lbus interface.

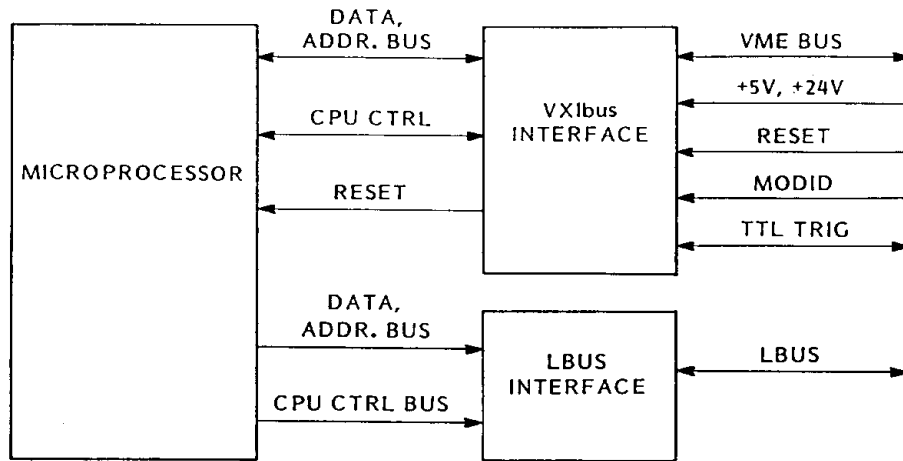

Figure 4-1, 1260 Smart Card Block Diagram

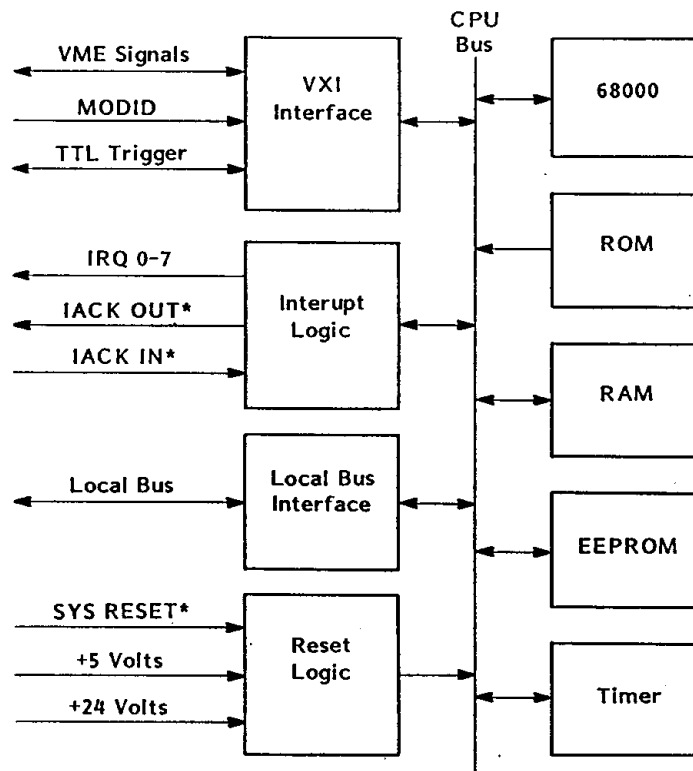

Figure 4-2, 1260 Microprocessor Block Diagram

Theory of Operation

Power Suppliers

DC power for the 1260-01 is derived from the VXI backplane via its host switch card. A +5V supply is used to operate all of the logic on the Master and Slave boards. A +24V supply is used to supply relay coil drive, and the +24V supply is monitored by U11b on the 1260-01 to ensure the relay coil drive voltage is available.

Microprocessor Block

The microprocessor block accepts commands from the VXIbus, interprets the commands and sends the required data to the appropriate relay card via the Lbus interface. A simplified block diagram is given in Figure 4-2. The microprocessor is a Motorola MC68000 operating at 8 MHz. This block also contains ROM, RAM, EEPROM, address decoding, interrupt logic, a counter/timer and general purpose input and output ports.

The program memory consists of two devices, U33 and U34. These devices provide 64K by 16 (optionally 128K by 16) of program memory as selected by W2. The OE\ of U33 and U34 is controlled by a PAL, U2, and programmed as follows:

MLOE\ goes low when R/W\ is high and LDS\ is low .

MHOE\ goes low when R/W\ is high and UDS\ is low.

The system RAM consists of U114 and U115. These devices provide 32K by 16 of memory. The OE\ of U114 and U115 is also derived from U24 in addition to their WR\ signals. U24 is programmed as follows:

MLWE\ goes low when R/W\ and LDS\ are low .

MUWE\ goes low when R/W\ and UDS\ are low.

The EEPROM is an 8K by 8 device and is configured for 6800 peripheral timing. PWE\ goes low when R/W\ is low and the clock E is high. The non-volatile memory's CE\ is qualified by U21a with NVENB\ which is generated by the reset circuitry. This prevents false writes to the EEPROM during power up and power down sequences ensuring memory integrity. The time delay between writes to the EEPROM is controlled by the system software.

Address decoding is performed by a PAL, U23. This device provides the necessary logic to map the other devices into the

microprocessors memory map. This device also provides the necessary DTACK\ or VPA\ signals for the microprocessor depending on whether the selected device is a 16 bit device or a 6800 peripheral. LDTACK\ is an input to U23, and is used to insert wait states when an Lbus cycle is accessed. The fourth and final function provided by U23 is to detect an interrupt cycle from the states of FC0\ and FC1\ and dropping the VPA\ line.

The microprocessor is configured to support up to seven interrupts without requiring the polling of devices to determine the interrupt. These seven sources are encoded onto three lines by U108 which in turn drives the IPL0 - 2 lines of the microprocessor.

All time dependent tasks are controlled by a counter\timer which is a Motorola 6840 CTC. This is mapped as a 6800 peripheral. The timer is configured by the microprocessor, and generates interrupts at a programmed interval. During normal operation, the timer is programmed to interrupt the microprocessor every 10 mS. Note the interrupt response latency of the microprocessor is expected to vary by some small amount.

The microprocessor system has one general purpose input port, and two general purpose output ports of 8 lines each. These ports are mapped as part of the VXIbus interface and use 6800 timing. The input port, U110, is used to read the status of the VXIbus interface state machine, and the status of the +24V on the backplane in conjunction with U11b. This port also reads the status of the VXIbus chassis receiver mechanism safety switches, if fitted, and the checkin signal used to put the microprocessor in self test mode. The safety switch input is protected by R111, Q3 and Q4, while R112 acts as a pullup when the switches are not used. U106 is an output port which is used along with U1, U2 and U3 to select which VXIbus defined TTLTRG line will be used to trigger the switching system. U109 is an output port to the VXIbus state machine that clears the trigger input latch, the trigger output, and the check output used in self-test mode.

The Reset Circuits

The reset circuit provides a reliable signal under the most difficult situations. The circuit consists of a voltage reference, VR1, which provides a nominal 1.23 voltage level, U11d, which senses when the +5V supply drops below 4.5 volts and discharges the reset timing capacitor, C2, via Q2. As the +5V supply is applied to the board, the output of U11d is held low until the supply reaches a nominal 4.75 volts, at which time it goes high. This signal is inverted by U11c which in turn drives Q2. As long as the +5V line is below +4.75 volts, the gate of Q2 is held high and prevents C2 from charging. If, at any time the +5V supply drops below 4.5 volts due to the hysteresis provided by Z4d, the gate of Q2 is

again pulled high, and the transistor discharges C2 restarting a reset cycle. CR1 holds the voltage across C2 to 0.6 volts above the reference voltage to reduce the time required to discharge the capacitor. U11a senses the voltage across the reset timing capacitor C2, and drives the HALT\ line from which all other reset signals are derived. This comparator also provides hysteresis due to Z4c to prevent oscillation as the capacitor voltage crosses the reference voltage. The HALT\ signal is the hardwired logical-OR of three signals. Q1 buffers the reset signal from the VXIbus backplane and drives HALT\. U111d buffers the low +5V sense signal from U11d and also drives HALT\. U111a inverts HALT\ to provide the non-inverted RESET signal while U111c buffers HALT\ to provide the board's inverted RESET\ signal. U111b and Q100 provide a high powered BPRST\ signal for the switching cards in the 1260 Series switching system via the Lbus. The +24V supply from the backplane is divided by Z2b, Z2c and R102 and compared to the reference voltage by U11b. This comparator drives the general purpose input port which is read by the microprocessor.

VXI Interface

The 1260-01 implements a VXI message-based device protocol. The VXI Interface contains the circuitry necessary to pass commands, data, and TTLTRG synchronization signals between the VXI bus and the 68000 microprocessor.

The VXI interface is accomplished using three busses; the external VXI bus, an internal replica of the VXI bus, and the microprocessor's bus. The data lines for the two VXI busses are connected using U10 and U100 for the data lines. Similarly, U8 and U17 buffer the address and control signals. Data bus transfers are controlled by sequencer U26. S1 is used to select the logical address for the module, while U7 and U103 decode the external address and address modify lines.

The internal VXI bus is connected to the microprocessor's bus through several registers, as defined in the VXI specifications. Actual interfacing of the registers to the 68000's bus is accomplished using U23 to control the handshake, U113 as an address decoder, and U109 as a general purpose register. The other VXI-defined registers are implemented as follows:

ID and Device Type Registers	U19
Status and Control Register	U28
Protocol Register	U19
Response Register	U29

Data Low Register	U9 and U101
Event Register	U20
Logical Address Register	U102

TTLTRG lines are used by external devices to open and close the signal paths, as specified by previously received SLIST commands from the Slot 0 controller. Each of the TTLTRG lines corresponds to a different "channel" number.

The microprocessor selects TTLTRG lines through address decoder U113, register 4106, and multiplexers U1 and U3. U1 is used for output, while U3 is used for input. U2 is a buffer which drives the selected output TTLTRG lines.

The Lbus Interface

The Lbus interface is the vehicle through which the microprocessor controls the relay cards in the system. It is a state machine which transmits the microprocessor's address and data serially through the Lbus to the switching modules in the switching system. The state machine makes the transfer of data to and from the relay latches look as though they are memory mapped in the microprocessors address space, and because of the ability to add wait states to the microprocessors's bus cycle, this process is entirely transparent to the user.

The Lbus interface state machine is implemented in a master and slave configuration, where the master is part of the microprocessor card and slaves are part of each relay card. The master state machine is implemented in two 22V10 PALs, three shift registers and three differential line drivers. U14 is the primary state machine and controls the state transitions for all data transfer activities. The master state machine has 27 states, where state S0 is the dormant state. When the state machine detects that its select line (LBUS\) and AS\ input are both low, it will proceed to state S1; otherwise it will remain at state S0. During state S1, LD/SH\ is lowered and the 13 lowest address lines are loaded into U22 and U112. During states S2 and S14, the address data is shifted through a multiplexer, U13, and line driver U4 onto the Lbus. This data is received by all relay cards in the system, and the four most significant bits of the 13 are used to select a specific card.

If the microprocessor was executing a write cycle, the data would be loaded into data shift register U12 during state S1. This register would be held in its hold mode until state S18 where it is allowed to shift its contents out via the multiplexer, U13, and line driver U4 to the Lbus. Alternatively, if the microprocessor was executing a read cycle, then data shift register U12 would shift in

the data from the slave state machine during states S17 through S24, and hold the data for states S25 and S26 to allow the microprocessor to read the data back. In both cases, the state machine generates the LDTACK\ signal for the microprocessor, which is combined with the other DTACK\ signals in the address decoder PAL U23, making data transfers to the slaves transparent to the microprocessor program.

Each slave relay card has a slave state machine. These state machines track the master state machine during the address transfer portion of a data transfer cycle. The slaves receive five signals from the master which are:

- a. Clock, which only toggles during a transfer cycle to reduce noise induced into the relay cards.
- b. A/D, which distinguishes between address and data transfers.
- c. R/W, which distinguishes between read and write cycles.
- d. STROBE, which transfers the newly written data into the relay latches at the end of a write cycle.
- e. DATA, which is a bi-directional line for transferring address and data between master and slaves.

The slave state machines in the system remain dormant until the master needs to transfer data to or from one of them. The master applies a clock signal to the Lbus, and raises the A/D line to indicate the start of a transfer. As a result, the slave state machines will lag the master by one state, and has only 26 states. Note that the following description of the slave state machines use the 1260-40 switching module as an example, and the reference designators referred to apply to this assembly only. The principles of operation are, however, identical for all relay assemblies within the 1260 Series.

The slave state machine is implemented in a 22V10 PAL, U52, and it tracks the states and provides the control signals for the switching module. When U52 receives a clock signal and A/D is high, it proceeds from state S0 to S1 through to S13 and starts clocking the address data into shift registers U62 and U61 using the CLKADDR signal. From state S14 to the end of the transfer, CLKADDR remains high, maintaining the address data at the shift register's outputs. The four highest address bits transferred to the slave are routed to a comparator, U56, and compared to the board address as set by SW1. If there is a match, BOARDENA goes high indicating that the data to be read or written pertains to this card. BOARDENA is read by the state machine U52, and if it is high during state S14, the state machine

will proceed to state S15. If it is not, then it will return to state S0.

If the state machine proceeds to state S15 and a write cycle is being executed, then CLKDENA goes high from state S16 until S21 and U53 gates its CLOCK input on and drives the CLKIN signal. CLKIN is gated to the correct input shift register through U54 and U55, as determined by the lower order address bits from U62 and U61. A9 is used to split the address space on the board between the relay space and the identification byte space. During the slave's state S24, the master will raise the STROBE line for one state, transferring the shift register's data into the relay latch. The relay latch then drives a sinking current driver to control the relay coil.

If a read cycle is being executed and applies to the relay board, CLKDENA goes high from state S15 to S21, and U53 gates its CLOCK input on and drives the CLKOUT signal. CLKOUT drives all of the read back shift registers. During state S15, SH/LD\ goes low and the data at the parallel inputs of the shift registers is loaded in. The relay data is derived from the relay coil drive voltage, and is divided by a 220K and 47K resistor set. The identification byte register is also loaded and shifted out, but its inputs are wired to a specific value used by the system to identify the type of card being accessed. Each read back shift register's output is routed to a multiplexer, U70, U71 and U72. The required output is selected by the address as presented by U62 and U61. This data is routed to the line driver U51 which is enabled by U53's DIN/OUT\ signal which goes low when CLKDENA is high and RD/WR\ is high.

Chapter 5

Drawings

401951, -003	PCB Assy, L-Bus Jumper	5-2
431951	Schematic, L-Bus Jumper	5-3
401901	PCB Assy, 1260 Master CPU (VXI Rev. 1.2).....	5-4
431901	Schematic, 1260 Master CPU (VXI Rev. 1.2)	5-6
401901-003	PCB Assy, 1260 Master CPU (Ver. 1, VXI Rev. 1.3)	5-19
431901-003	Schematic, 1260 Master CPU (Ver. 1, VXI Rev. 1.3).....	5-21
401901-005	PCB Assy, 1260 Smart CPU, Rev. 1.3	5-34
431901-005	Schematic, 1260 Smart CPU, Rev. 1.3.....	5-35

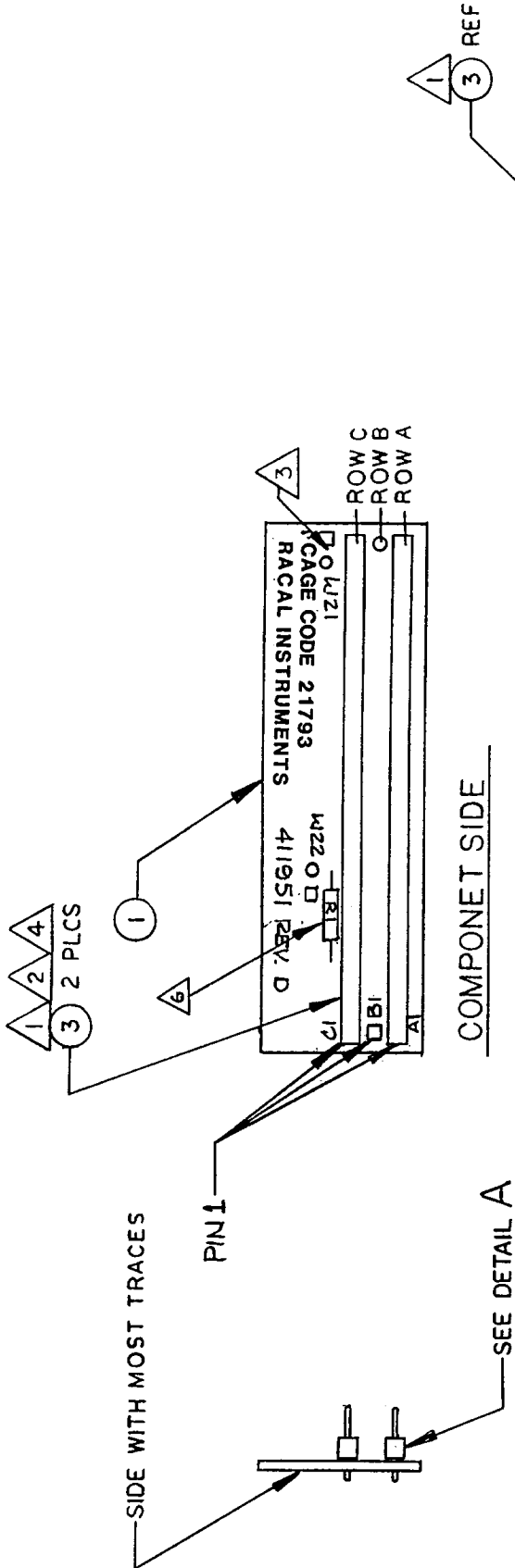

- △ 1 INSTALL JUMPER W21 (ITEM 5) ON 401951-003 ONLY.
- △ 2 INSTALL ITEM 3 IN ROWS A & C FOR 401951. INSTALL ITEM 3 IN ROWS A & B FOR 401951-003.
- △ 3 INSTALL ITEM 3 WITH SHORT LEADS IN PCB PERPENDICULAR AND FIRMLY SEATED ON PCB AFTER SOLDERING.
- △ 4 INSTALL RESISTOR R1 ON 401951 ONLY.
- △ 5 INK STAMP CURRENT REVISION ON CIRCUIT SIDE. INK STAMP -003 IF BUILDING 401951-003
- △ 6 BREAK ITEM 3 TO 22 POSITIONS PRIOR TO INSTALLATION. DISCARD EXTRA PIECE.

DOC. NO.	DESCRIPTION
401951	PCB ASSY, L-BUS JUMPER, P4
401951-003	PCB ASSY, BUS GRANT JUMPER, P3

DETAIL A
SCALE 4:1

RACAL Instruments, Inc. 4 Goodyear St., Irvine, CA. 92718-2002 DOCUMENT TITLE			
PCB ASSY, L-BUS JUMPER			
SIZE	CODE IDENT NO.	DOCUMENT NO.	REV.
B	21793	401951,-003	E
SCALE	2:1	SHEET	1 OF 3

PROPRIETARY NOTICE
 THIS DOCUMENT AND THE TECHNICAL DATA HEREIN DISCLOSED ARE PROPRIETARY TO RACAL INSTRUMENTS, INC. REPRODUCTION, TRANSMISSION, OR DISTRIBUTION OF THIS DOCUMENT OR THE DATA HEREIN, WITHOUT THE EXPRESS WRITTEN PERMISSION OF RACAL INSTRUMENTS, INC. IS PROHIBITED. THIS DOCUMENT IS THE PROPERTY OF RACAL INSTRUMENTS, INC. AND IS LOANED TO YOUR COMPANY FOR YOUR USE ONLY. IT IS NOT TO BE REPRODUCED, COPIED, OR TRANSMITTED IN ANY FORM OR BY ANY MEANS, ELECTRONIC OR MECHANICAL, INCLUDING PHOTOCOPYING, RECORDING, OR BY ANY INFORMATION STORAGE AND RETRIEVAL SYSTEM. RACAL INSTRUMENTS, INC. HAS BEEN DEVELOPED AT PRIVATE EXPENSE, AND HAS BEEN EVALUATED FOR INCORPORATION INTO OTHER PRODUCTS WHICH SPECIFY PROCEDURES AND OTHER DOCUMENTS FROM RACAL INSTRUMENTS, INC.

NOTES: UNLESS OTHERWISE SPECIFIED

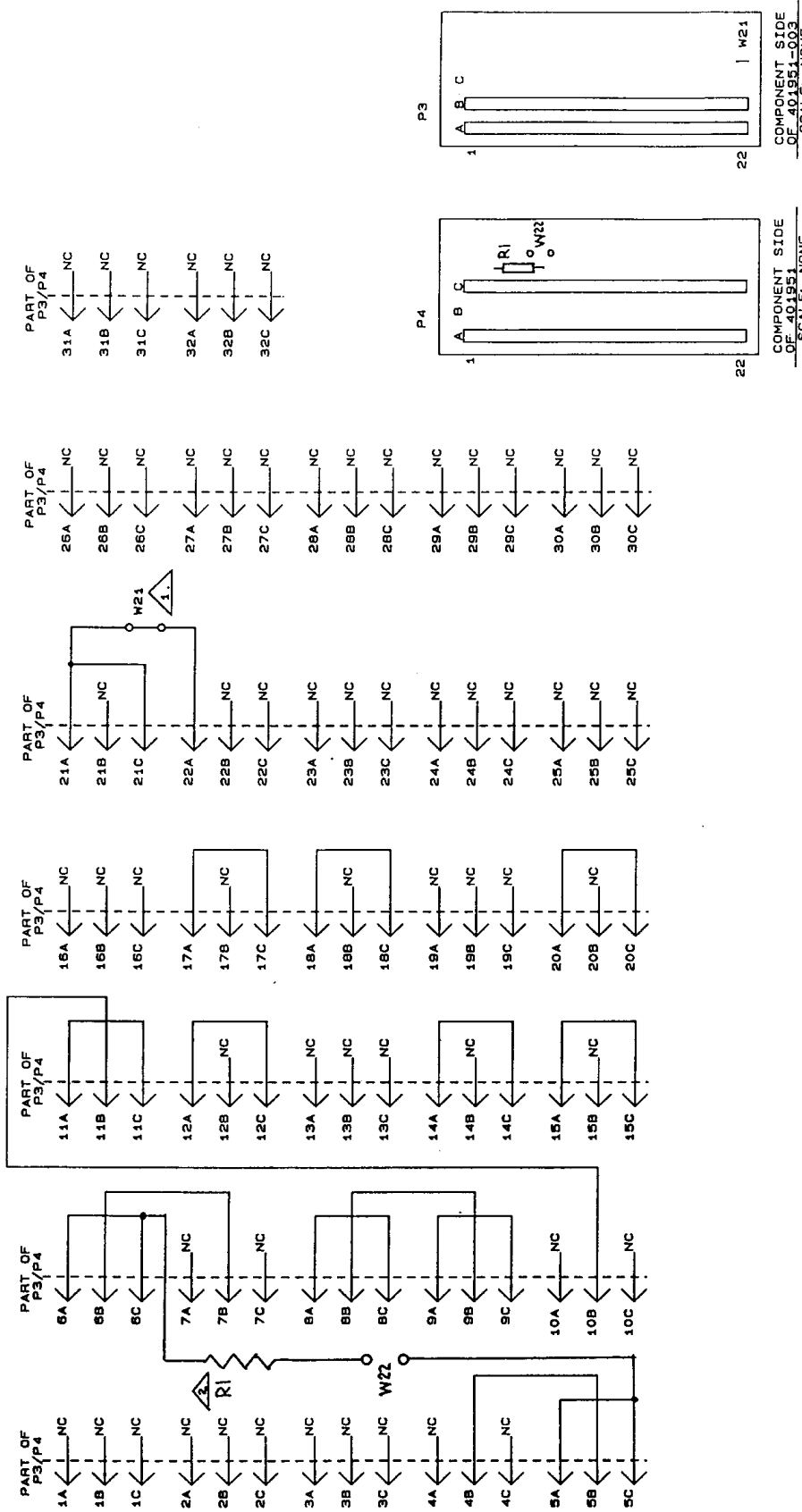

RACAL Instruments, Inc.
4 Goodyear St., Irvine, CA. 92718-2002

DOCUMENT TITLE
SCHEM.. LBUS JUMPER

SIZE	CODE IDENT NO.	DOCUMENT NO.	REV.
B	21793	431951	C

SCALE: _____ SHEET 1 OF 1

PROPRIETARY NOTICE

THIS DOCUMENT AND THE TECHNICAL DATA HEREIN CONTAINED THEREIN ARE PROPRIETARY TO RACAL INSTRUMENTS, INC. AND SHALL NOT BE DISCLOSED OR REPRODUCED IN ANY MANNER WITHOUT THE EXPRESS WRITTEN PERMISSION OF RACAL INSTRUMENTS, INC. BE USED, RELEASED OR DISCLOSED IN WHOLE OR IN PART, OR USED TO SOLICIT QUOTATIONS FROM A COMPETITIVE SOURCE OR USED FOR REPRODUCTION IN ANY MANNER WITHOUT THE WRITTEN PERMISSION OF RACAL INSTRUMENTS, INC. THE INFORMATION HEREIN HAS BEEN DEVELOPED AT PRIVATE EXPENSE AND MAY ONLY BE USED FOR PURPOSES OF ENGINEERING EVALUATION AND FOR INCORPORATION INTO TECHNICAL SPECIFICATIONS AND OTHER DOCUMENTS WHICH SPECIFY CALIBRATION AND OTHER DOCUMENTS FROM RACAL INSTRUMENTS, INC.

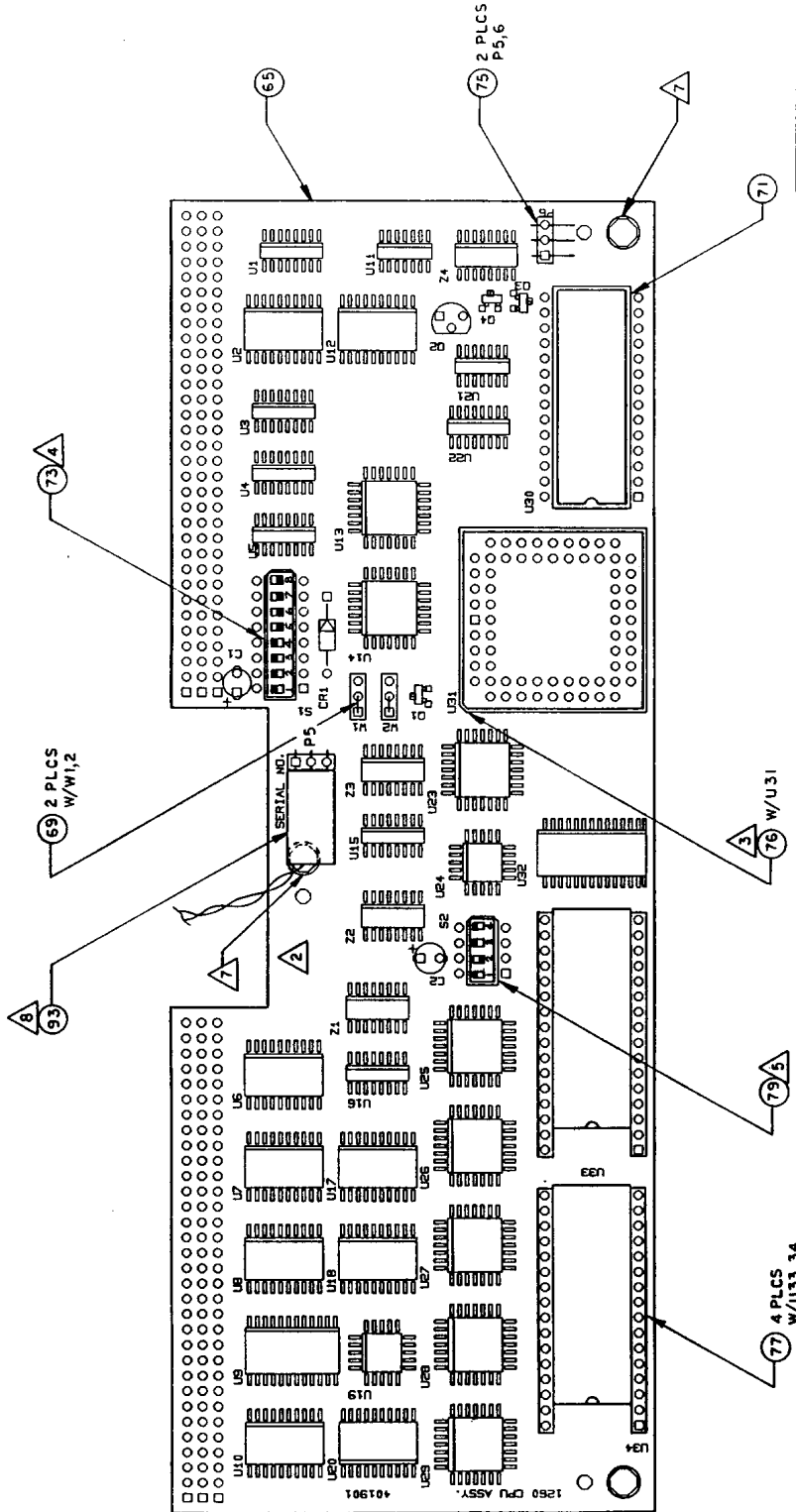

PROPRIETARY NOTICE
 THIS DOCUMENT AND THE TECHNICAL DATA HEREIN ARE THE PROPERTY OF RACAL INSTRUMENTS, INC. AND SHALL NOT, WITHOUT THE WRITTEN PERMISSION OF RACAL INSTRUMENTS, BE REPRODUCED, COPIED, OR TRANSMITTED IN ANY FORM OR BY ANY MEANS, ELECTRONIC OR MECHANICAL, INCLUDING PHOTOCOPYING, RECORDING, OR BY ANY INFORMATION STORAGE AND RETRIEVAL SYSTEM. ANYONE OTHER THAN RACAL INSTRUMENTS, INC. WHO USES THIS DOCUMENT OR THE INFORMATION HEREIN FOR ANY PURPOSES OTHER THAN THAT SPECIFIED IN THE ORIGINAL DOCUMENTATION SHALL BE RESPONSIBLE FOR OBTAINING THE NECESSARY PERMISSIONS FROM RACAL INSTRUMENTS, INC.

Racal Instruments, Inc. 4 Goodyear St., Irvine, CA 92718-2002			
DOCUMENT TITLE			
PCB ASSY, 1260 MASTER CPU			
SIZE	CODE IDENT NO.	DOCUMENT NO.	REV.
D	21793	401901	E
SCALE 2:1		SHEET	OF 4

COMPONENT SIDE

9. ALL COMPONENTS MUST NOT EXCEED THE HEIGHT OF .375 ABOVE THE COMPONENT SIDE OF BOARD.
 - ▲ INSTALL CABLE ASSY (ITEM 93) INTO P5 (ITEM 75).
 - ▲ INSTALL STANDOFF (ITEM 92) BEFORE P5,6 (ITEM 75).
 6. REFERENCE DESIGNATORS RANGE FROM 1 TO 99 FOR THE COMPONENT SIDE AND FROM 100 TO 199 FOR THE SOLDER SIDE OF THE PCB.
 - ▲ ITEM 79, S2, SWITCHES 1,3,4 ARE "ON" POSITION, SWITCH 2 IS "OFF" POSITION.
 - ▲ ITEM 73, S1, SWITCHES 1,2,3,4 ARE "ON" POSITION, SWITCHES 5,6,7,8 ARE "OFF" POSITION.
 - ▲ NOTE POSITION OF ANGLE ON SOCKET OF U31.
 - ▲ INK STAMP SERIAL NUMBER ON COMPONENT SIDE IN INDICATED AREA.
 1. REFERENCE SCHEMATIC 431901.
- NOTES UNLESS OTHERWISE SPECIFIED

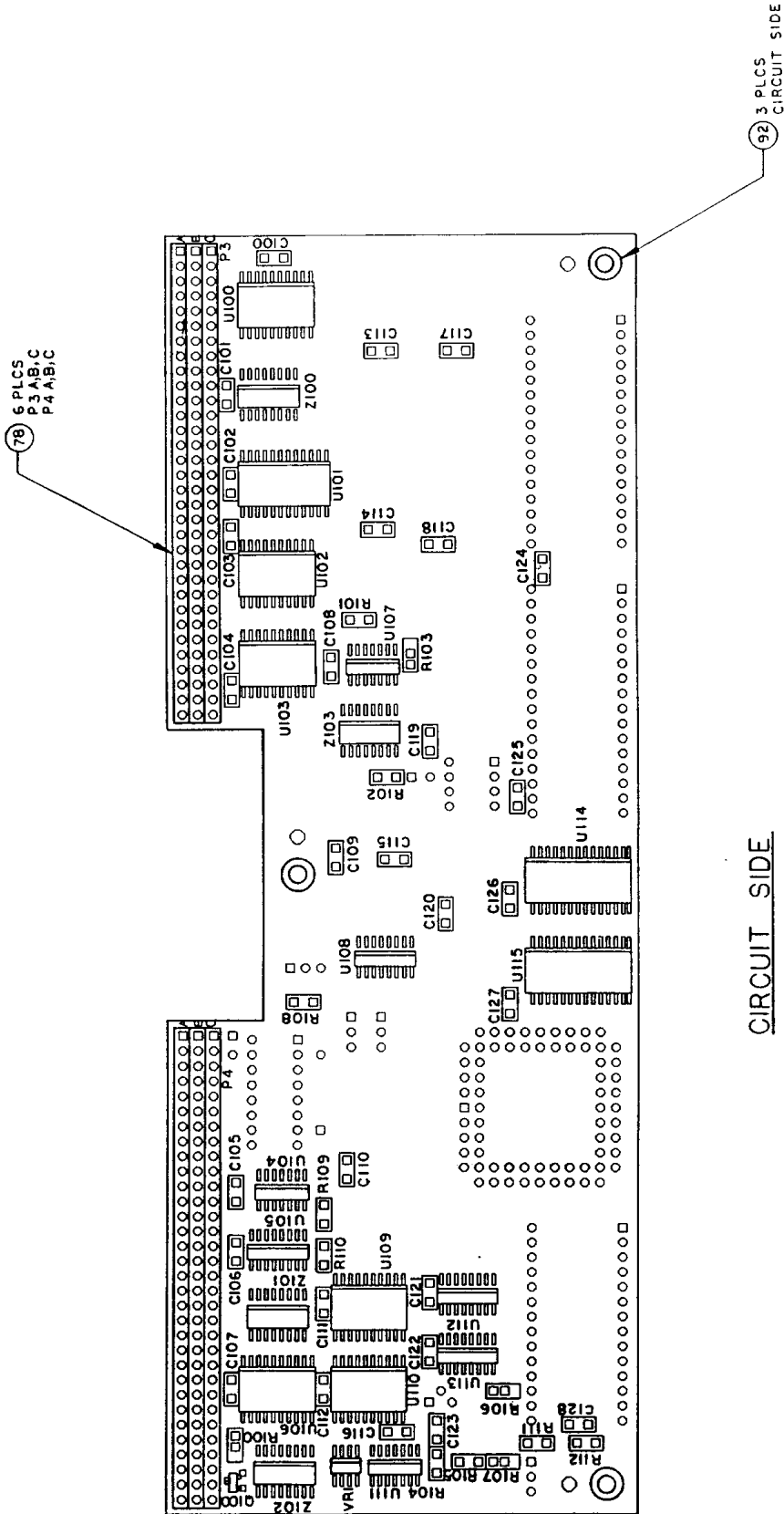

SIZE	CODE IDENT NO.	DOCUMENT NO.	REV.
D	21793	401901	E
SCALE 2:1		SHEET 2	OF 4

REF. DES.	IC TYPE	+5V PIN NO.	GND PIN NO.
U114, 115	62256	28	14
U108	74LS148	16	8
U107	74938	14	7
U105	26LS92	16	8
U104	74LS74	14	7
U34	231167 (27512)	30, 32	16
U33	231166 (27512)	30, 32	16
U32	56C65	28	14
U31	MC68000CP-B	14, 52	16, 17, 56, 57
U30	6840P	14	1
U29	231155 (20RA10)	28	15
U28	231156 (20RA10)	28	15
U27	231157 (22V10)	28	14
U26	231158 (22V10)	28	14
U25	231159 (22V10)	28	14
U24	231160 (18L8)	20	10
U23	231161 (22V10)	28	14

REF. DES.	IC TYPE	+5V PIN NO.	GND PIN NO.
U22, 112	74HCT166	16	8
U21	74HC32	14	7
U20, 106, 109	74LS374	20	10
U19	231162 (18L8)	20	10
U15	74F109	16	8
U14	231163 (22V10)	28	14
U13	231164 (22V10)	28	14
U12	74HCT299	20	10
U11, 111	LM339	3	12
U10, 100	74ALS645A-1	20	10
U9, 101	74LS652	24	12
U8, 17, 102, 110	74LS244	20	10
U7, 18, 103	74F521	20	10
U4, 5	26LS31	16	8
U3	74LS151	16	8
U2, 6	74LS641-1	20	10
U1, 16, 113	74LS139	16	8

Z4, 103
W2
VR1
S2
U34, 115
R112
Q4, 100
P6
CR1
C2, 129
HIGHEST REF. DES.

- REFERENCE DESIGNATORS RANGE FROM 1 TO 99 FOR THE COMPONENT SIDE AND FROM 100 TO 199 FOR THE SOLDER SIDE OF THE PCB.
- CAPACITOR VALUES ARE IN OHMS.
- RESISTOR VALUES ARE IN MICROFARADS. +/-20%. 50V UNLESS OTHERWISE SPECIFIED.
- RESISTOR NETWORKS ARE IN OHMS. +/-2%.

NOTES: UNLESS OTHERWISE SPECIFIED

PROPRIETARY NOTICE
 THIS DOCUMENT AND THE TECHNICAL DATA HEREIN DISCLOSED ARE PROPRIETARY TO RACAL INSTRUMENTS INC. AND NO PART OF THIS DOCUMENT IS TO BE REPRODUCED OR TRANSMITTED IN ANY FORM OR BY ANY MEANS, ELECTRONIC OR MECHANICAL, INCLUDING PHOTOCOPYING, RECORDING, OR BY ANY INFORMATION STORAGE AND RETRIEVAL SYSTEM, WITHOUT THE WRITTEN PERMISSION OF RACAL INSTRUMENTS INC. THIS DOCUMENT IS THE PROPERTY OF RACAL INSTRUMENTS INC. AND IS LOANED TO YOU FOR YOUR USE ONLY. IT IS TO BE RETURNED TO RACAL INSTRUMENTS INC. AT THE END OF THE LOAN PERIOD. NO PART OF THIS DOCUMENT IS TO BE REPRODUCED OR TRANSMITTED IN ANY FORM OR BY ANY MEANS, ELECTRONIC OR MECHANICAL, INCLUDING PHOTOCOPYING, RECORDING, OR BY ANY INFORMATION STORAGE AND RETRIEVAL SYSTEM, WITHOUT THE WRITTEN PERMISSION OF RACAL INSTRUMENTS INC. THIS DOCUMENT IS THE PROPERTY OF RACAL INSTRUMENTS INC. AND IS LOANED TO YOU FOR YOUR USE ONLY. IT IS TO BE RETURNED TO RACAL INSTRUMENTS INC. AT THE END OF THE LOAN PERIOD.

Racal Instruments, Inc. 4 Goodyear St., Irvine, CA. 92718-2002			
DOCUMENT TITLE			
SCHEM., 1260 MASTER			
SIZE	CODE IDENT NO.	DOCUMENT NO.	REV.
B	21793	431901	C
SCALE			SHEET 1 OF 13

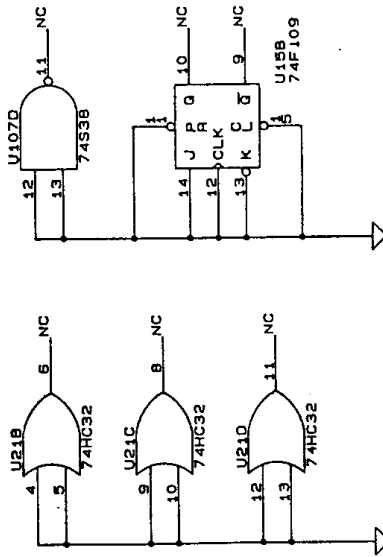
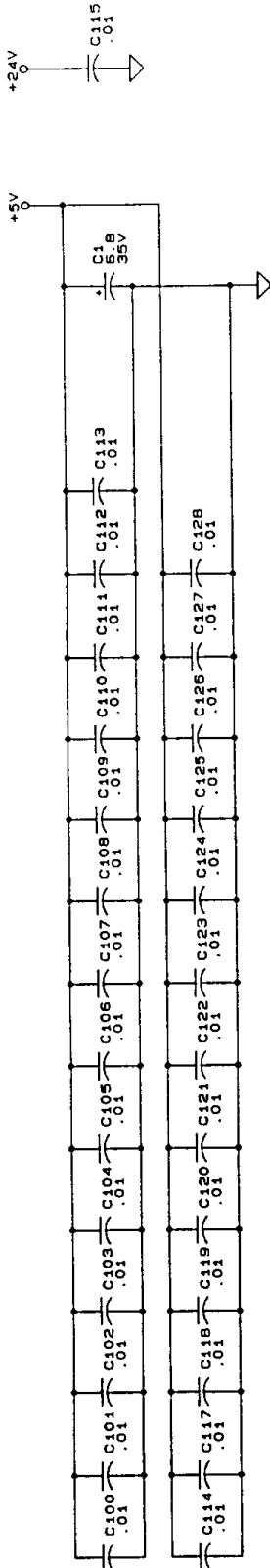

SIZE	CODE IDENT NO.	DOCUMENT NO.	REV.
B	21793	431901	C
SCALE		SHEET 2	OF 13

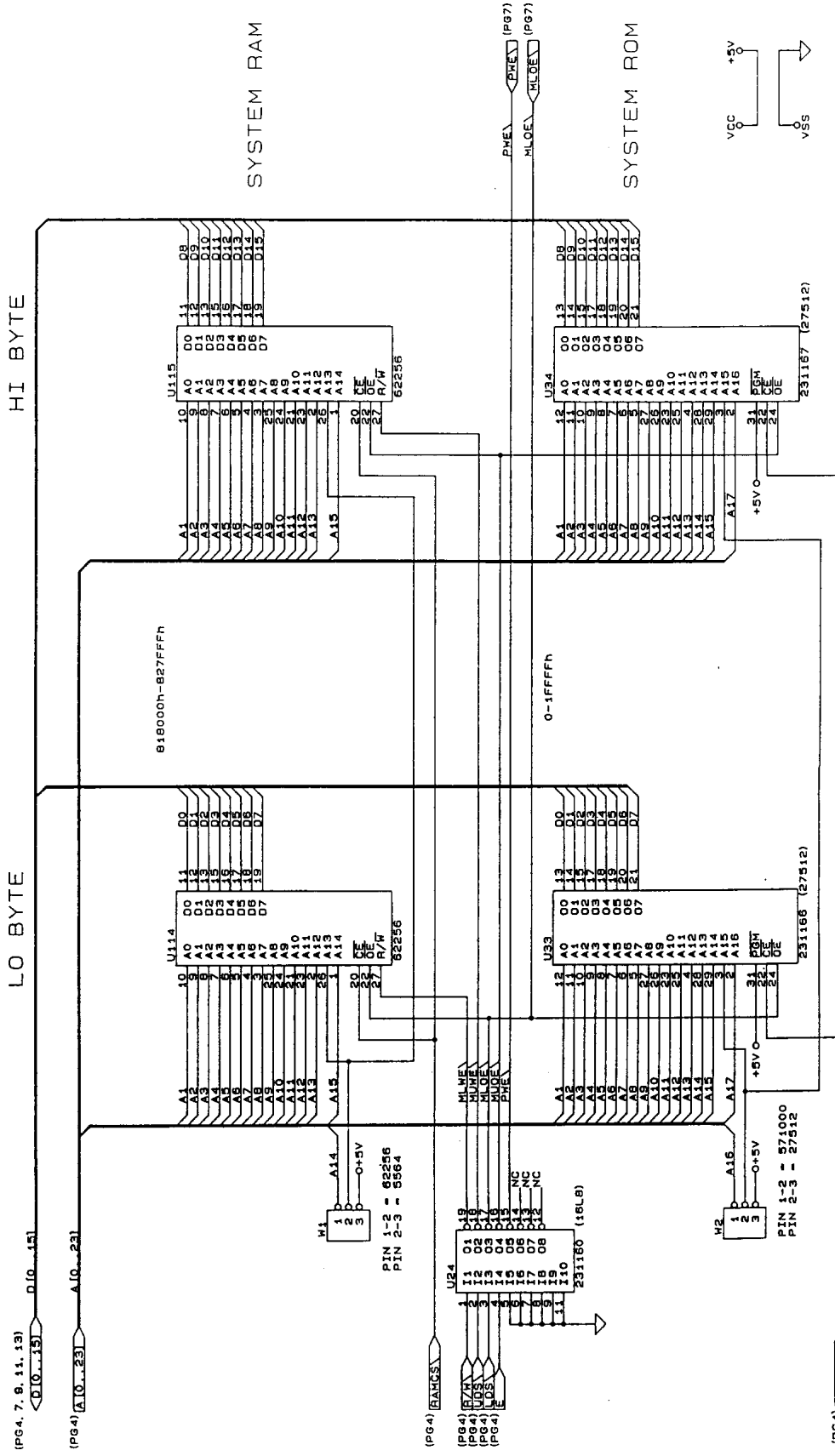

SIZE	CODE IDENT NO.	DOCUMENT NO.	REV.
B	21793	431901	C
SCALE		SHEET 3	OF 13

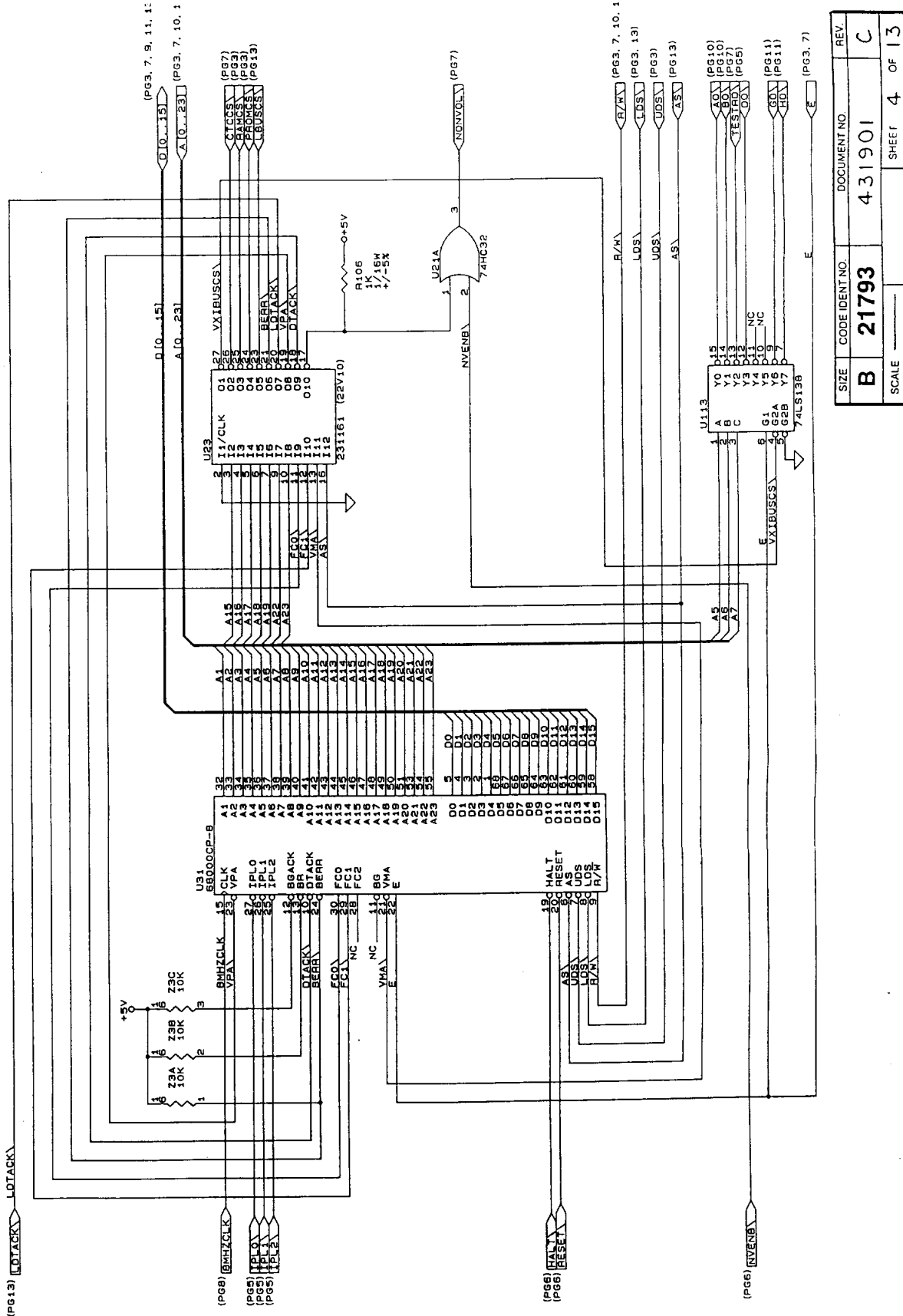

SIZE	CODE IDENT NO.	DOCUMENT NO.	REV.
B	21793	431901	C
SCALE		SHEET 4 OF 13	

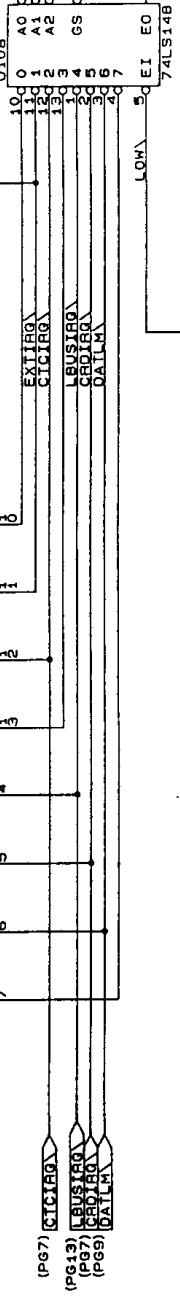
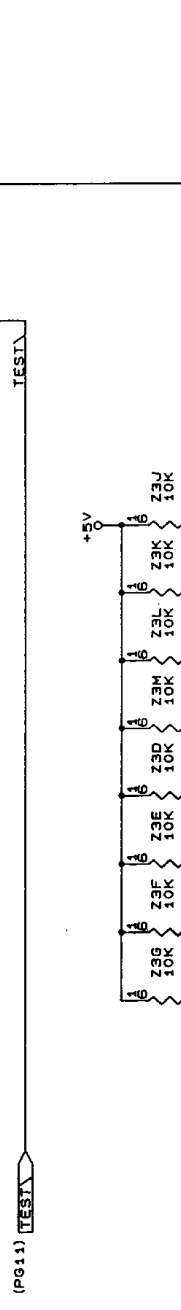
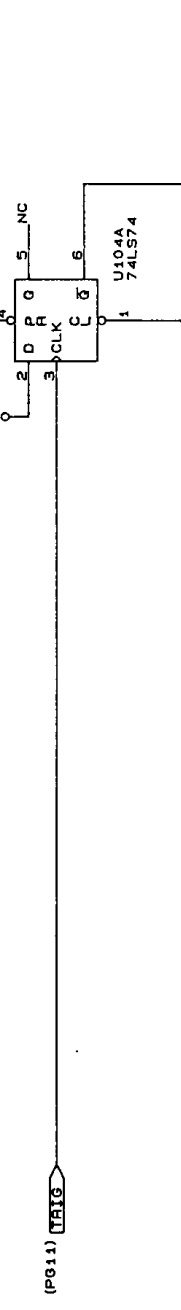
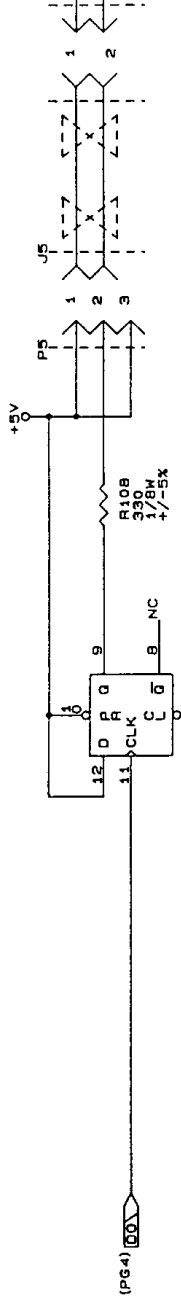
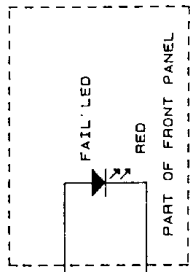

SIZE	CODE IDENT NO.	DOCUMENT NO.	REV.
B	21793	431901	C
SCALE		SHEET 5	OF 13

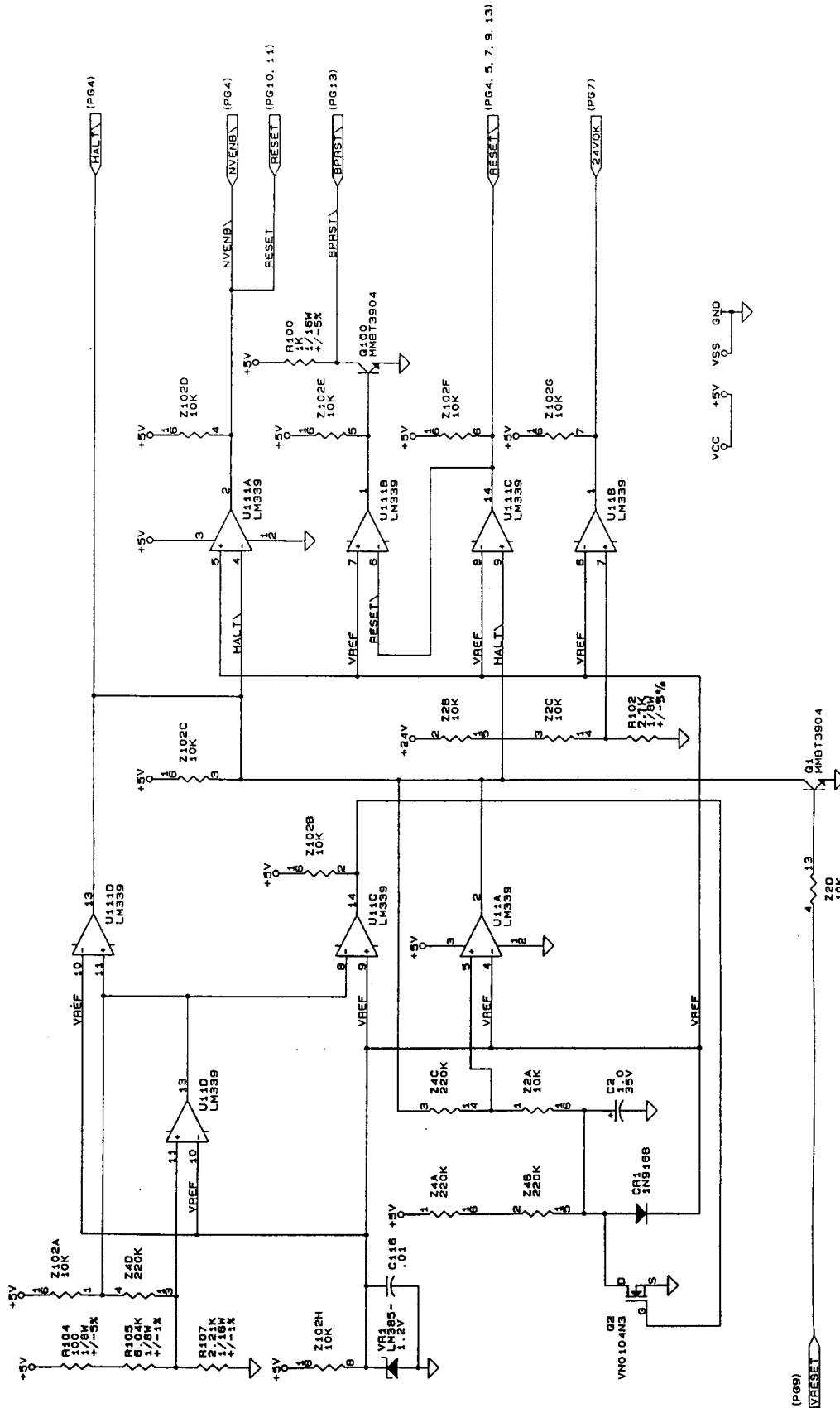

(P68)
VREF

SIZE	CODE IDENT NO.	DOCUMENT NO.	REV.
B	21793	431901	C
SCALE		SHEET	OF
		6	13

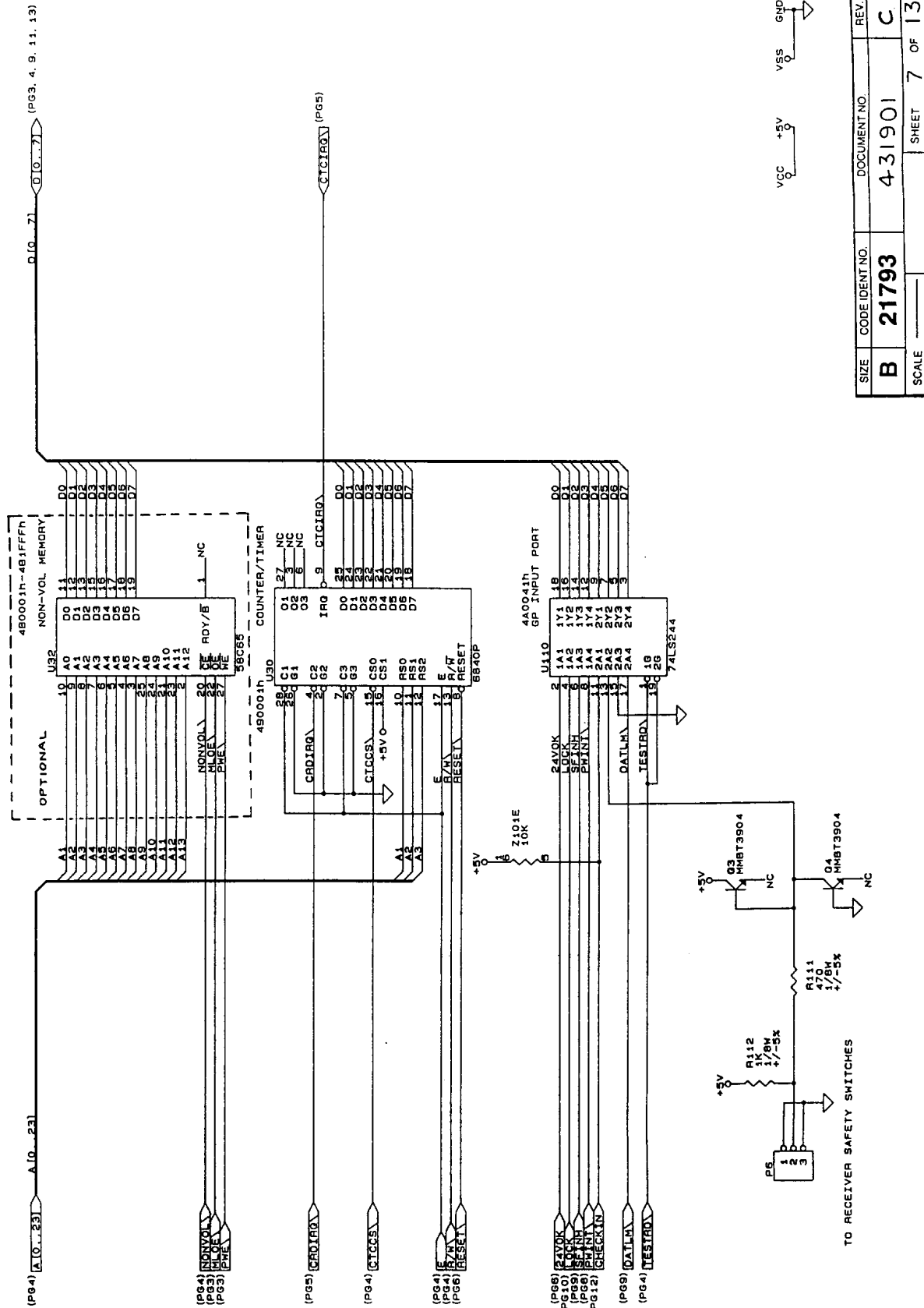

SIZE	CODE IDENT NO.	DOCUMENT NO.	REV.
B	21793	4-31901	C
SCALE	SHEET 7 OF 13		

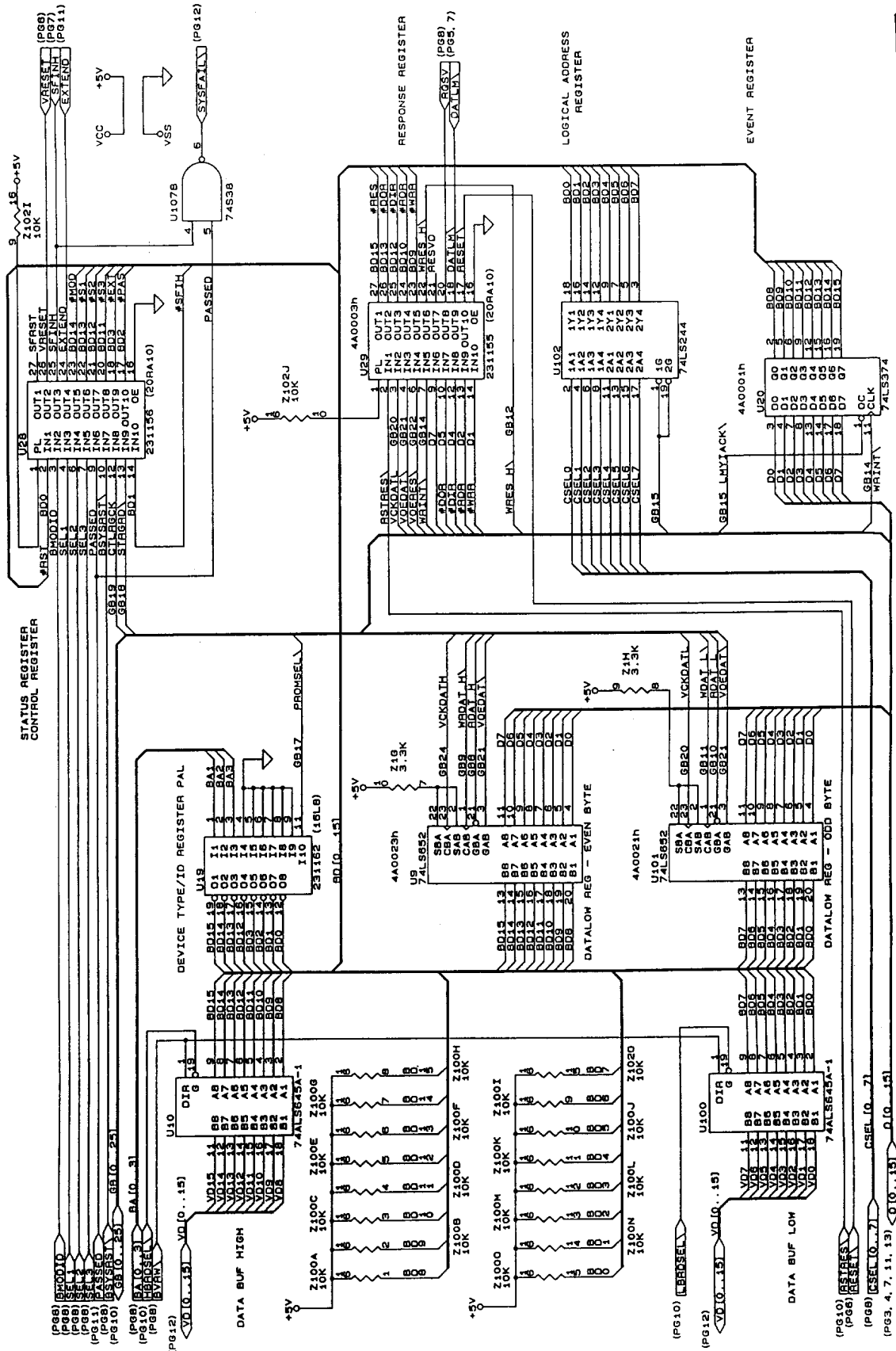

SIZE	CODE IDENT NO.	DOCUMENT NO.	REV.
B	21793	431901	C
SCALE		SHEET 9	OF 13

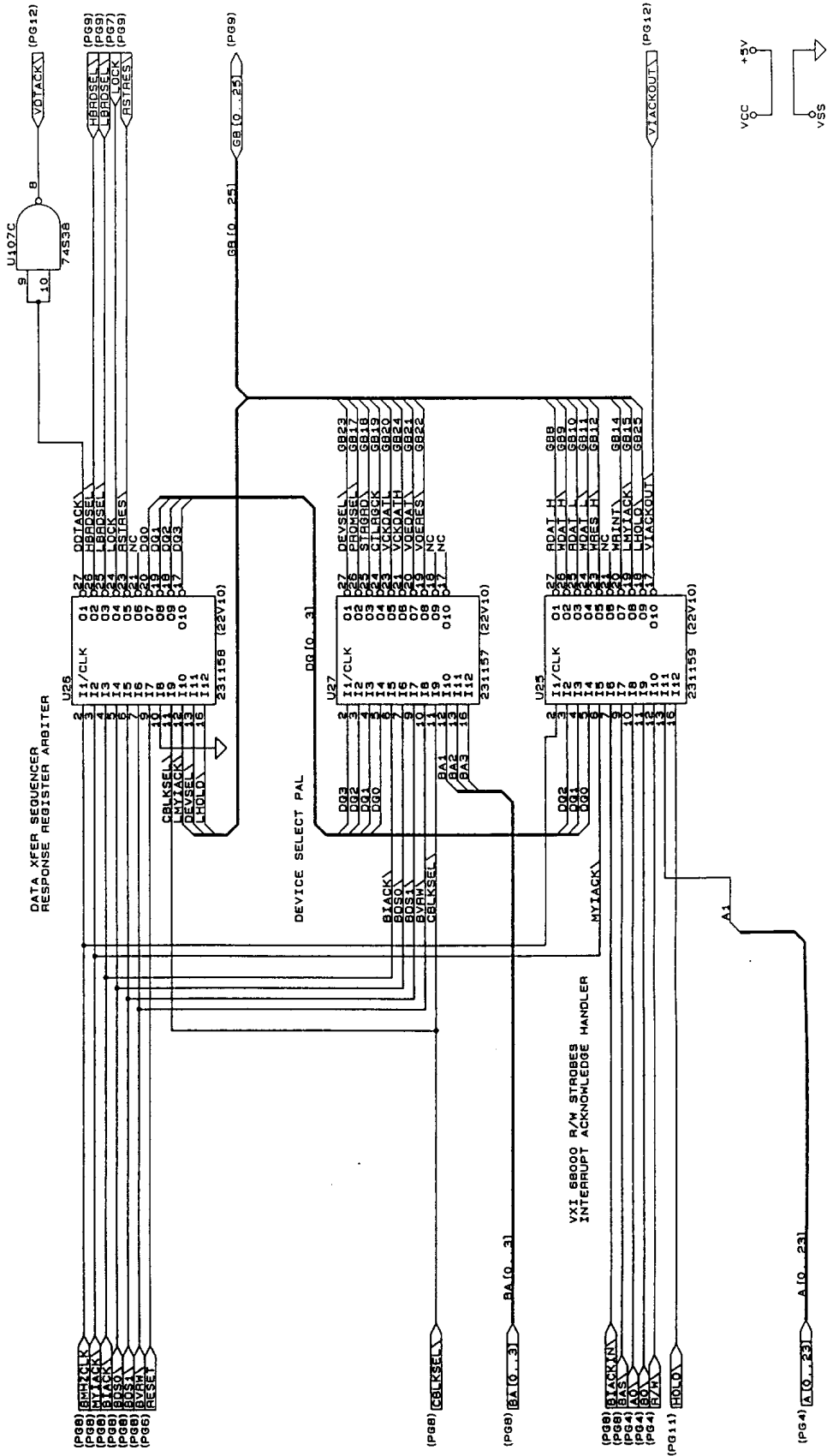

SIZE	CODE IDENT NO.	DOCUMENT NO.	REV.
B	21793	431901	C
SCALE		SHEET 10 OF 13	

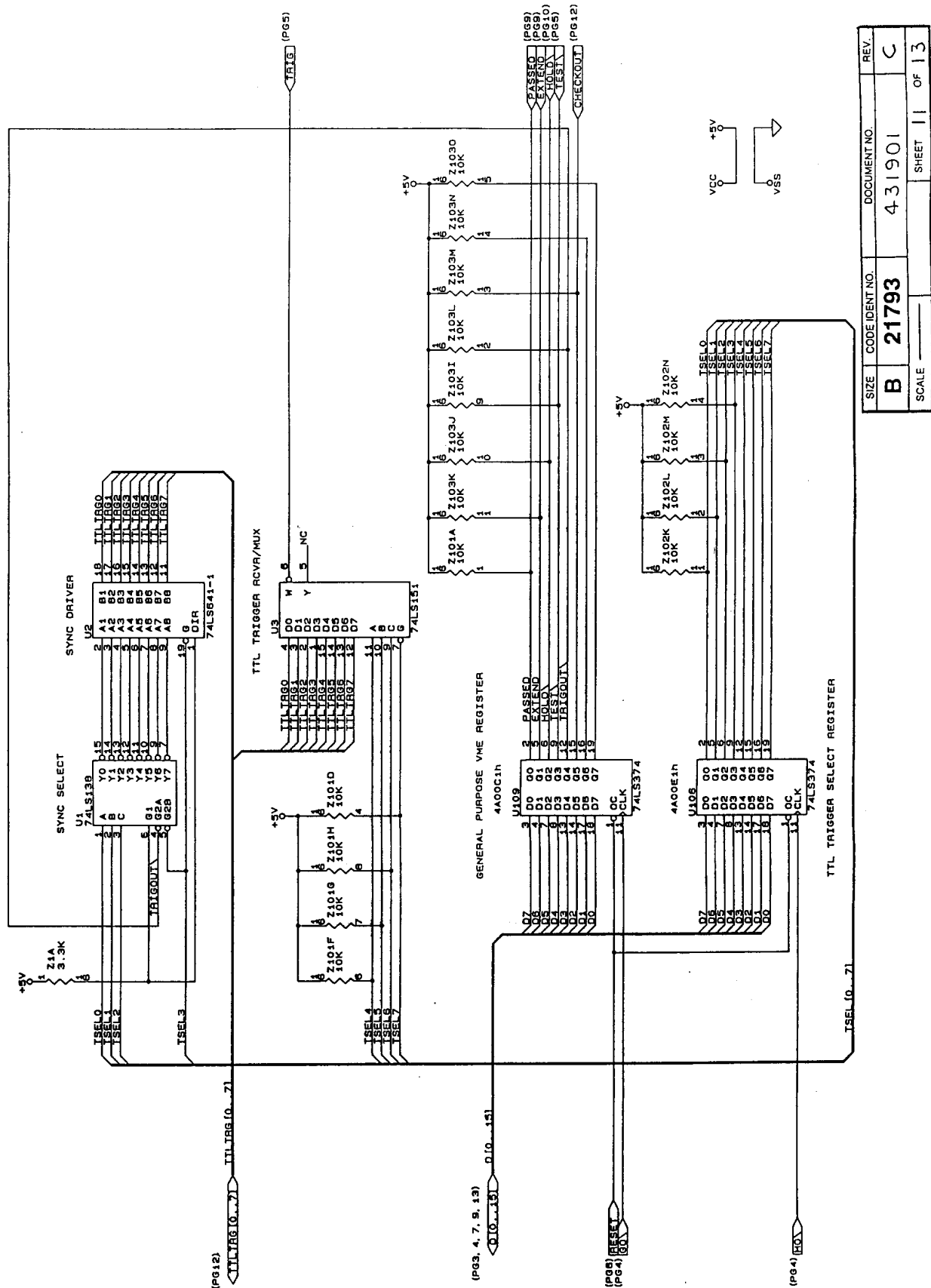

SIZE	CODE IDENT NO.	DOCUMENT NO.	REV.
B	21793	431901	C
SCALE		SHEET 11	OF 13

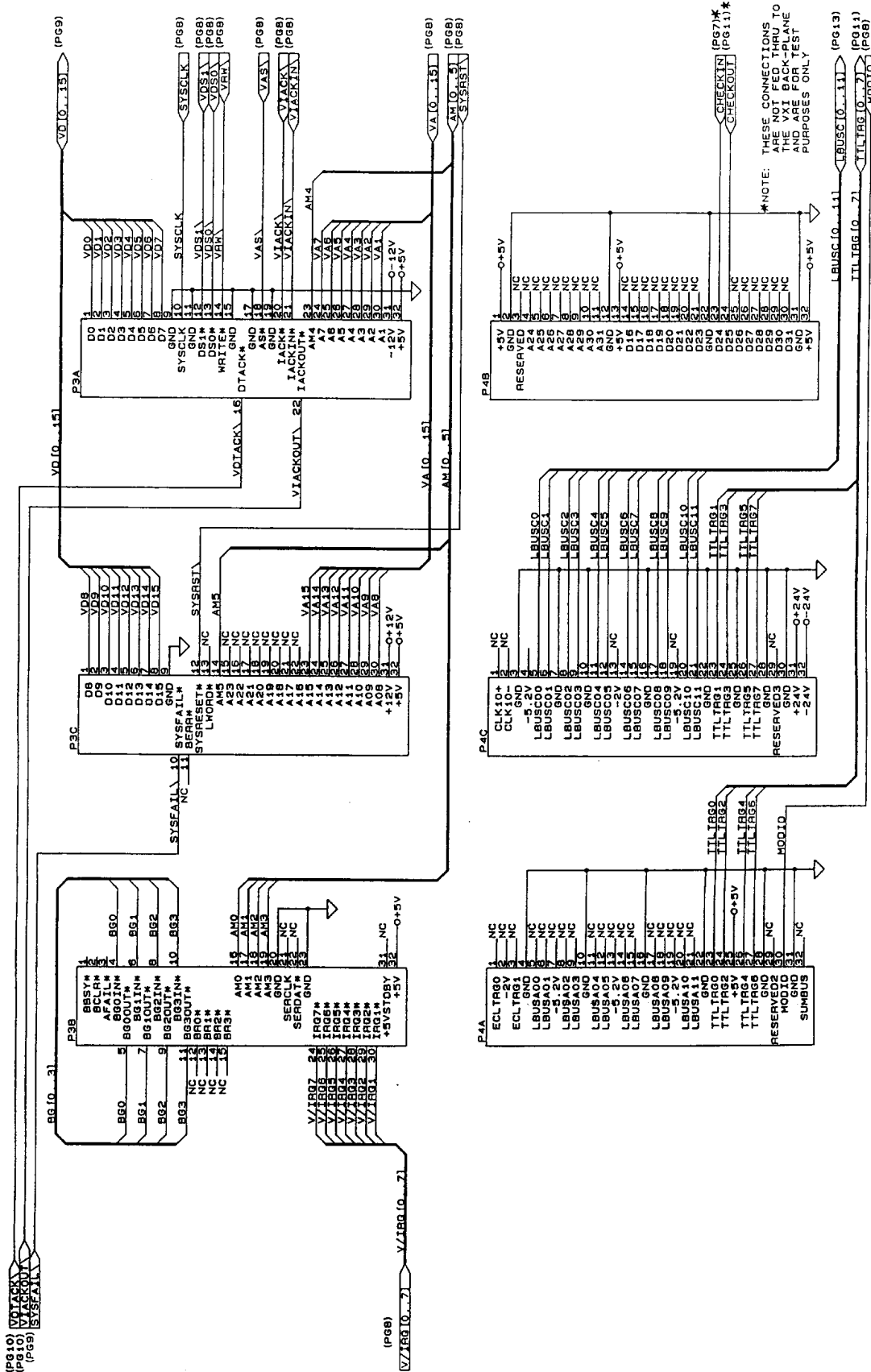

*NOTE: THESE CONNECTIONS ARE NOT FED THRU TO THE BOARD AND ARE FOR TEST PURPOSES ONLY.

SIZE	CODE IDENT NO.	DOCUMENT NO.	REV.
B	21793	431901	C
SCALE		SHEET 12	OF 13

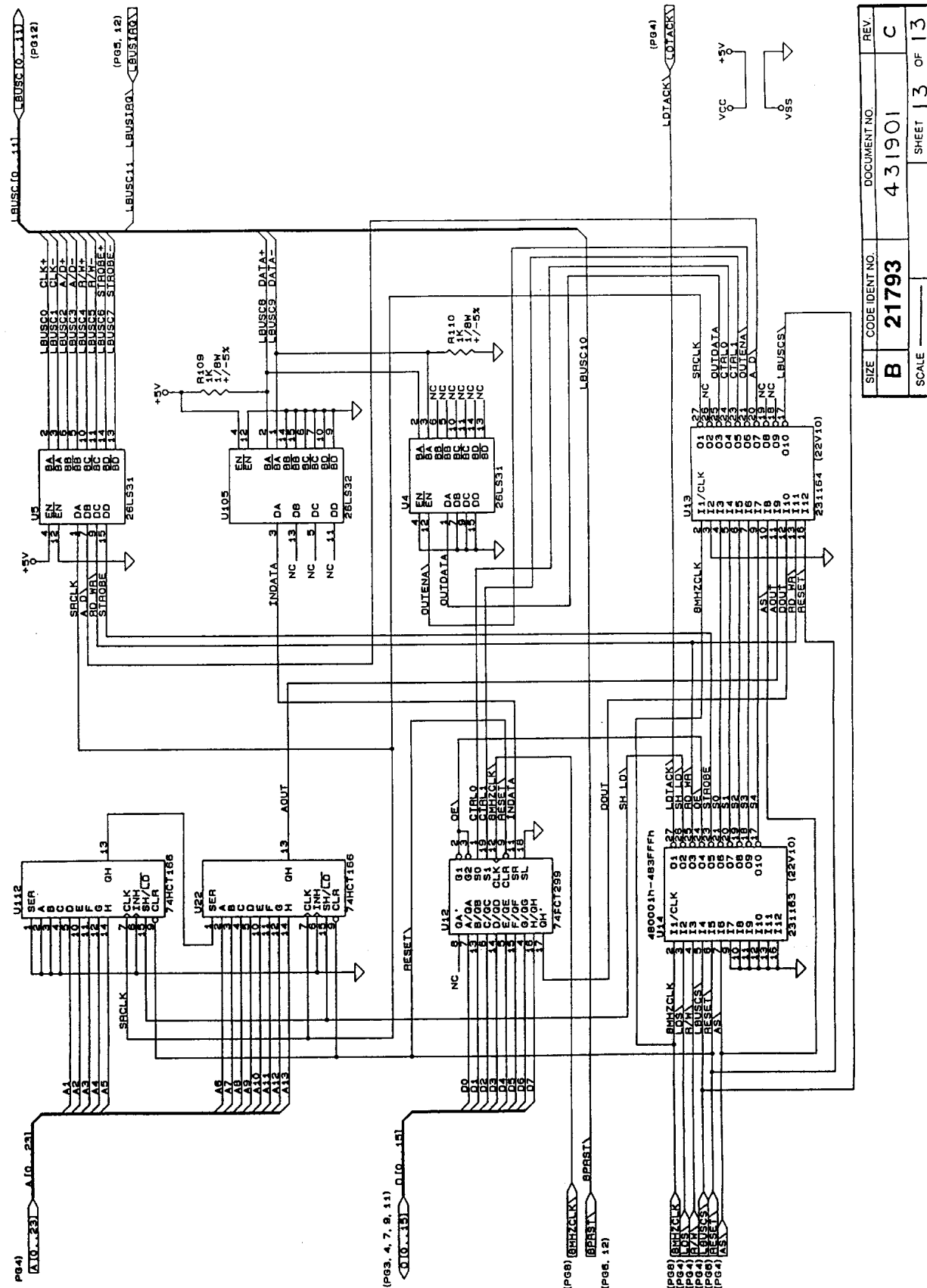

SIZE	CODE IDENT NO.	DOCUMENT NO.	REV.
B	21793	431901	C
SCALE		SHEET 13	OF 13

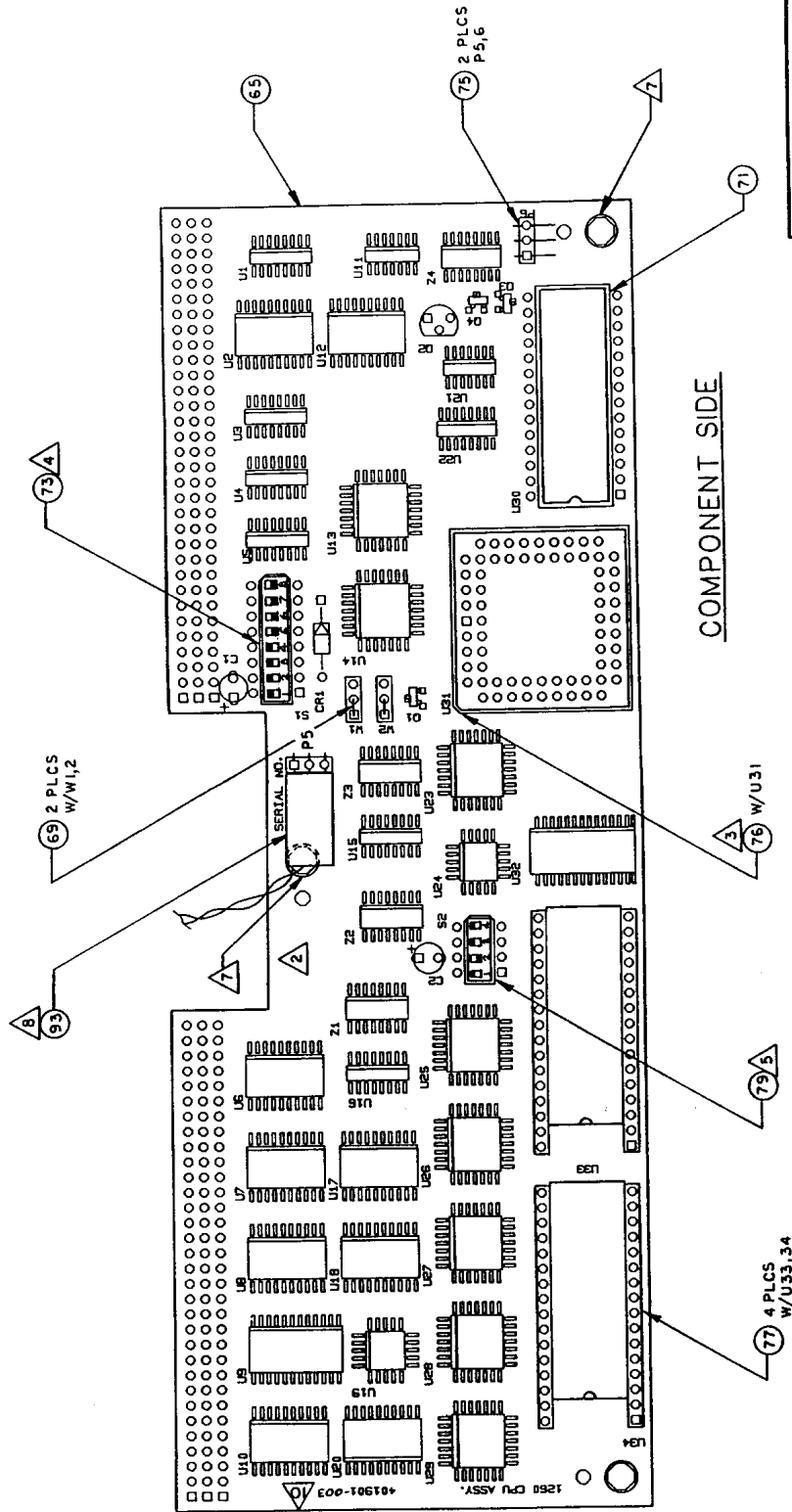

PROPRIETARY NOTICE
 THIS DOCUMENT AND THE TECHNICAL DATA HEREIN DISCLOSED ARE PROPRIETARY TO RACAL INSTRUMENTS, INC. NO PART OF THIS DOCUMENT IS TO BE REPRODUCED, COPIED, STORED, RETRIEVED, TRANSMITTED, OR USED IN ANY MANNER WITHOUT THE WRITTEN PERMISSION OF RACAL INSTRUMENTS, INC. THIS DOCUMENT IS THE PROPERTY OF RACAL INSTRUMENTS, INC. AND IS TO BE USED ONLY FOR THE MANUFACTURE OF PRODUCTS SPECIFICALLY IDENTIFIED HEREIN. IT IS NOT TO BE USED FOR REPRODUCTION OR FOR ANY OTHER PURPOSES. RACAL INSTRUMENTS, INC. IS NOT RESPONSIBLE FOR ANY DAMAGE TO PERSONS OR PROPERTY THAT MAY BE CAUSED BY THE USE OF THIS DOCUMENT. RACAL INSTRUMENTS, INC. IS NOT RESPONSIBLE FOR ANY DAMAGE TO PERSONS OR PROPERTY THAT MAY BE CAUSED BY THE USE OF THIS DOCUMENT.

Racal Instruments, Inc. 4 Goadyear St., Irvine, CA. 92718-2002			
DOCUMENT TITLE			
PCB ASSY, I260 MASTER CPU			
SIZE	CODE IDENT NO.	DOCUMENT NO.	REV.
D	21793	401901-003	C
SCALE 2:1			SHEET 1 OF 4

COMPONENT SIDE

10 INKSTAMP DASH ASSY NUMBER AND CURRENT REV. ON COMPONENT REV. ON COMPONENT SIDE IN INDICATED AREA.

9. ALL COMPONENTS MUST NOT EXCEED THE HEIGHT OF .375 ABOVE THE COMPONENT SIDE OF BOARD.

8. INSTALL CABLE ASSY (ITEM 93) INTO P5 (ITEM 75).

7. INSTALL STANDOFF (ITEM 92) BEFORE P56 (ITEM 75).

6. REFERENCE DESIGNATORS RANGE FROM 1 TO 99 FOR THE COMPONENT SIDE AND FROM 100 TO 199 FOR THE SOLDER SIDE OF THE PCB.

5. ITEM 79, 52, SWITCHES 1,3,4 ARE "ON" POSITION, SWITCH 2 IS "OFF" POSITION.

4. ITEM 73, 51, SWITCHES 1,2,3,4 ARE "ON" POSITION, SWITCHES 5,6,7,8 ARE "OFF" POSITION.

3. NOTE POSITION OF ANGLE ON SOCKET OF U31.

2. INK STAMP SERIAL NUMBER ON COMPONENT SIDE IN INDICATED AREA.

1. REFERENCE SCHEMATIC 431901-003.

NOTES: UNLESS OTHERWISE SPECIFIED

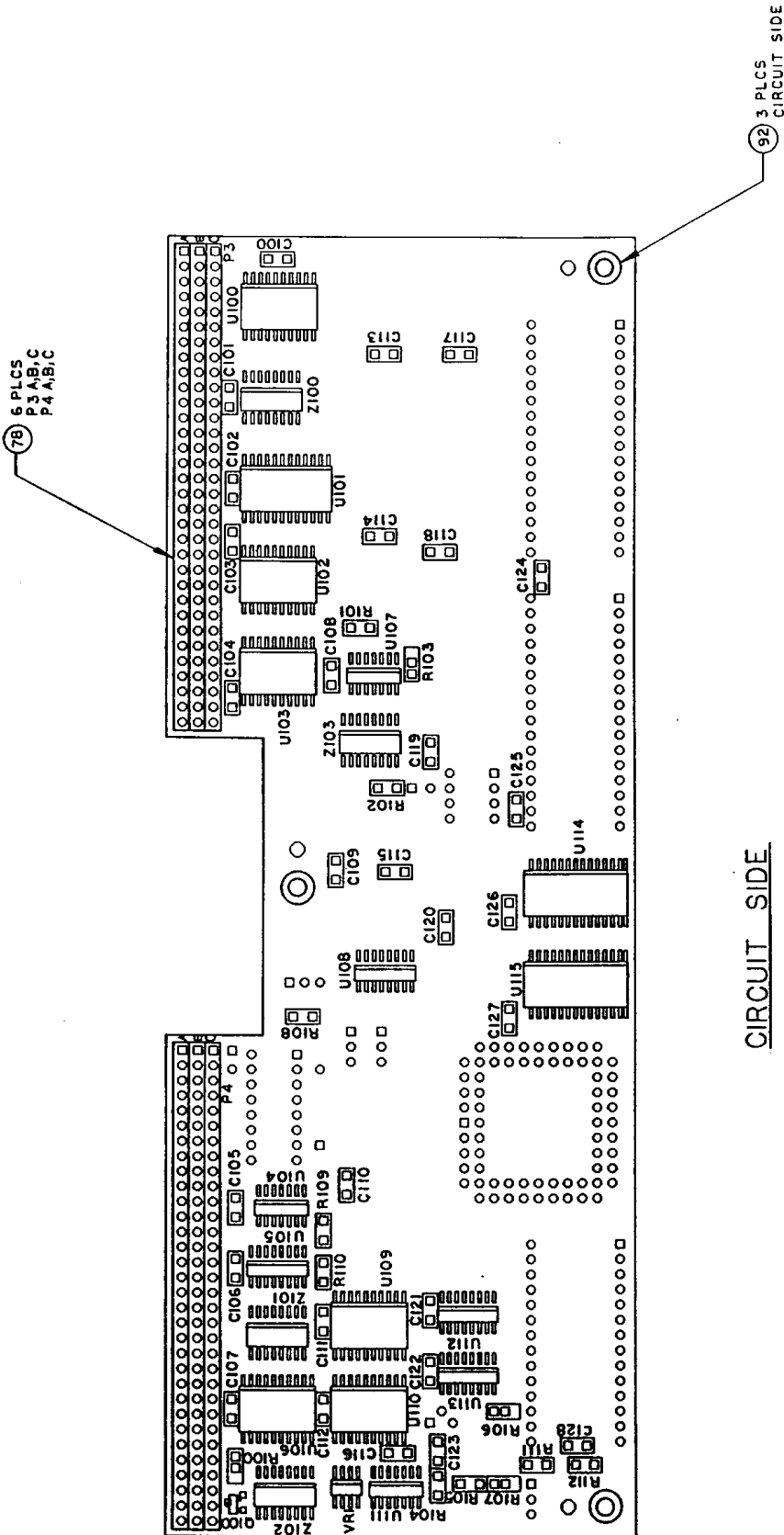

CIRCUIT SIDE

SIZE	CODE IDENT NO.	DOCUMENT NO.	REV.
D	21793	401901-003	C
SCALE 2:1		SHEET 2	OF 4

REF. DES.	IC TYPE	+5V PIN NO.	GND PIN NO.	REF. DES.	IC TYPE	+5V PIN NO.	GND PIN NO.
U114, 115	62256	28	14	U22, 112	74HCT166	16	8
U108	74LS148	16	8	U21	74HC32	14	7
U107	74S38	14	7	U20, 106, 108	74LS374	20	10
U105	28LS32	16	8	U19	231162 (16L8)	20	10
U104	74LS74	14	7	U15	74F109	16	8
U34	231167 (27S12)	30, 32	16	U14	231163 (22V10)	28	14
U33	231166 (27S12)	30, 32	16	U13	231164 (22V10)	28	14
U32	58C65	28	14	U12	74HCT299	20	10
U31	MC68000CP-8	14, 52	16, 17, 56, 57	U11, 111	LM339	3	12
U30	6840P	14	1	U10, 100	74ALS645A-1	20	10
U29	231155 (20RA10)	28	15	U9, 101	74LS652	24	12
U28	231156 (20RA10)	28	15	U8, 17, 102, 110	74LS244	20	10
U27	231157 (22V10)	28	14	U7, 18, 103	74F521	20	10
U26	231158 (22V10)	28	14	U4, 5	28LS31	16	8
U25	231159 (22V10)	28	14	U3	74LS151	16	8
U24	231160 (16L8)	20	10	U2, 6	74LS641-1	20	10
U23	231161 (22V10)	28	14	U1, 15, 113	74LS138	15	8

24, 103
M2
VR1
S2
U34, 115
R112
Q4, 100
P6
CR1
C2, 128
HIGHEST REF. DES.

- REFERENCE DESIGNATORS RANGE FROM 1 TO 99 FOR THE COMPONENT SIDE AND FROM 100 TO 199 FOR THE SOLDER SIDE OF THE PCB.
- RESISTOR VALUES ARE IN OHMS.
- CAPACITOR VALUES ARE IN MICROFARADS, +/-20%, 50V UNLESS OTHERWISE SPECIFIED.
- RESISTOR NETWORKS ARE IN OHMS, +/-2%.

NOTES: UNLESS OTHERWISE SPECIFIED

PROPRIETARY NOTICE
 THIS DOCUMENT AND THE TECHNICAL DATA HEREIN DISCLOSED ARE PROPRIETARY TO RACAL INSTRUMENTS INC. AND SHALL NOT, WITHOUT THE EXPRESS WRITTEN PERMISSION OF RACAL INSTRUMENTS INC., BE USED, REPRODUCED, COPIED, OR TRANSMITTED IN ANY FORM OR BY ANY MEANS FROM A COMPETITIVE SOURCE OR USED FOR MANUFACTURE BY ANYONE OTHER THAN RACAL INSTRUMENTS INC. THE INFORMATION HEREIN HAS BEEN DEVELOPED FOR THE PURPOSES OF ENGINEERING EVALUATION AND FOR INCORPORATION INTO TECHNICAL SPECIFICATIONS AND OTHER DOCUMENTS WHICH SPECIFY PROCUREMENT OF PRODUCTS FROM RACAL INSTRUMENTS INC.

Racal Instruments, Inc.			
4 Goodyear St., Irvine, CA 92718-2002			
DOCUMENT TITLE			
SCHEM., 1260 MASTER CPU			
SIZE	CODE IDENT NO	DOCUMENT NO	REV.
B	21793	431901-003	B
SCALE		SHEET	OF
		1	13

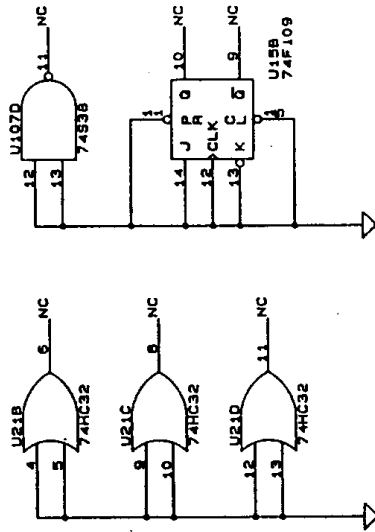
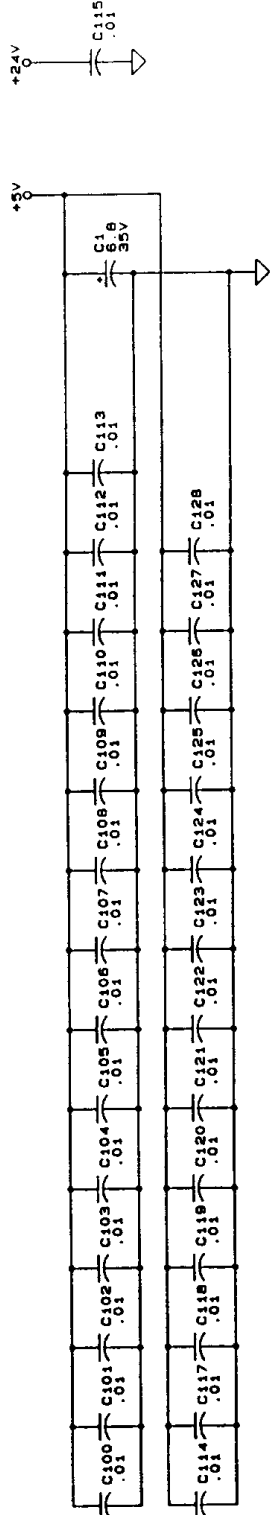

SIZE	CODE IDENT NO.	DOCUMENT NO.	REV
B	21793	431901-003	B
SCALE	SHEET 2 OF 13		

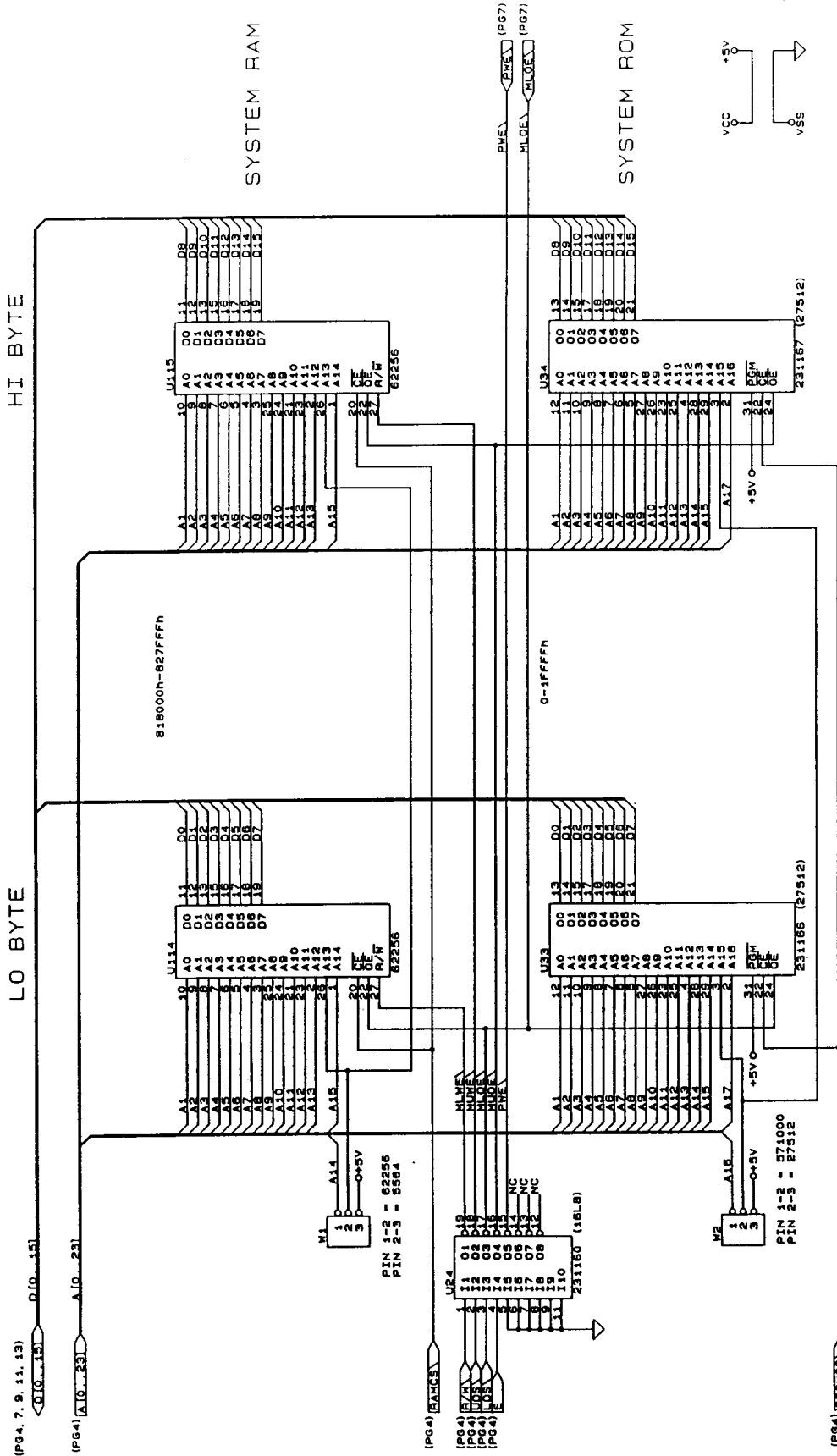

SIZE	CODE IDENT NO	DOCUMENT NO	REV
B	21793	431901-003	B
SCALE		SHEET 3	OF 13

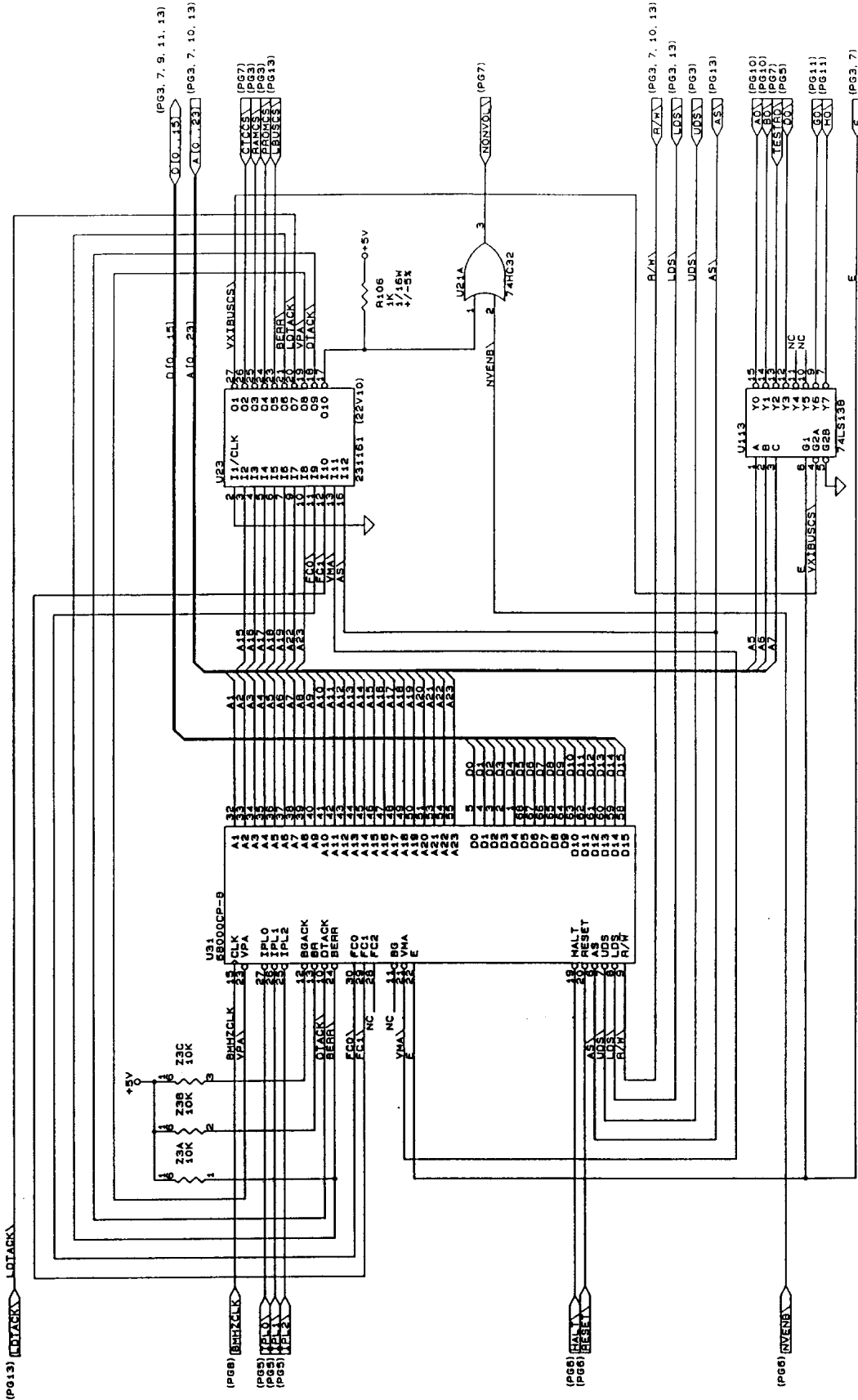

SIZE	CODE IDENT NO	DOCUMENT NO	REV
B	21793	431901-003	B
SCALE		SHEET	OF
		4	13

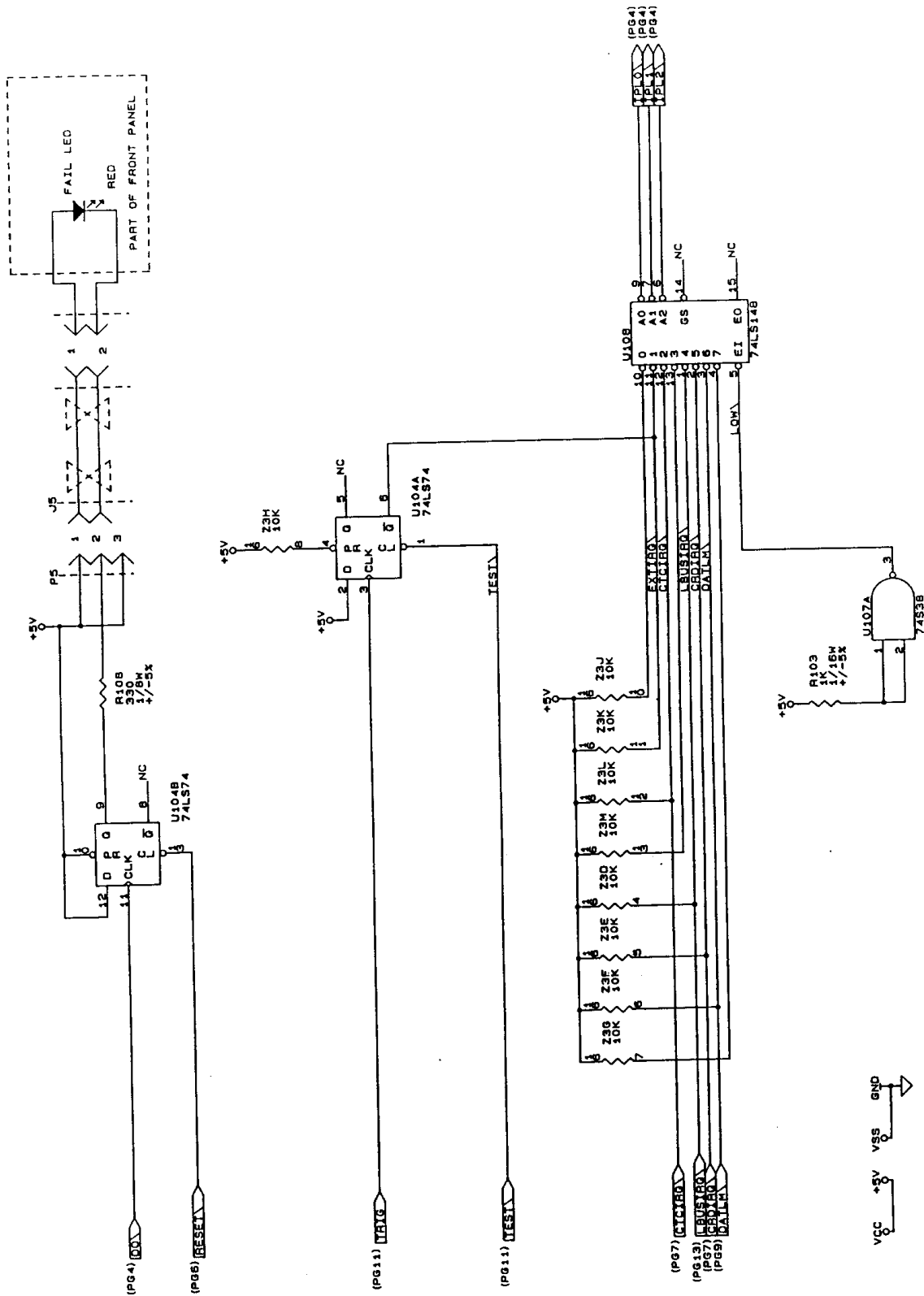

SIZE	CODE IDENT NO	DOCUMENT NO	REV
B	21793	4 31901-003	B
SCALE		SHEET 5	OF 13

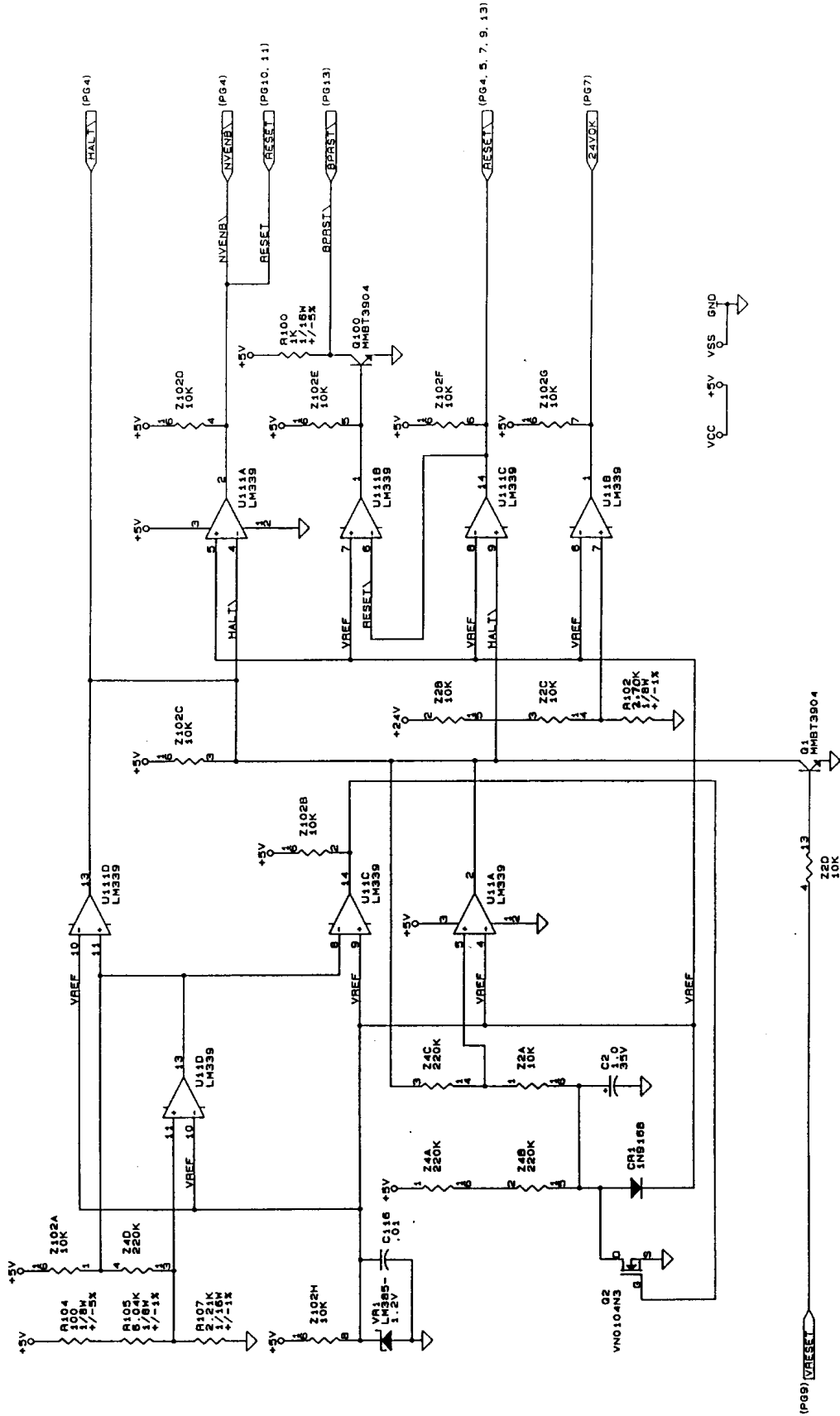

SIZE	CODE IDENT NO	DOCUMENT NO	REV
B	21793	431901-003	B
SCALE		SHEET 6	OF 13

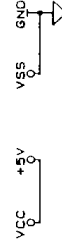
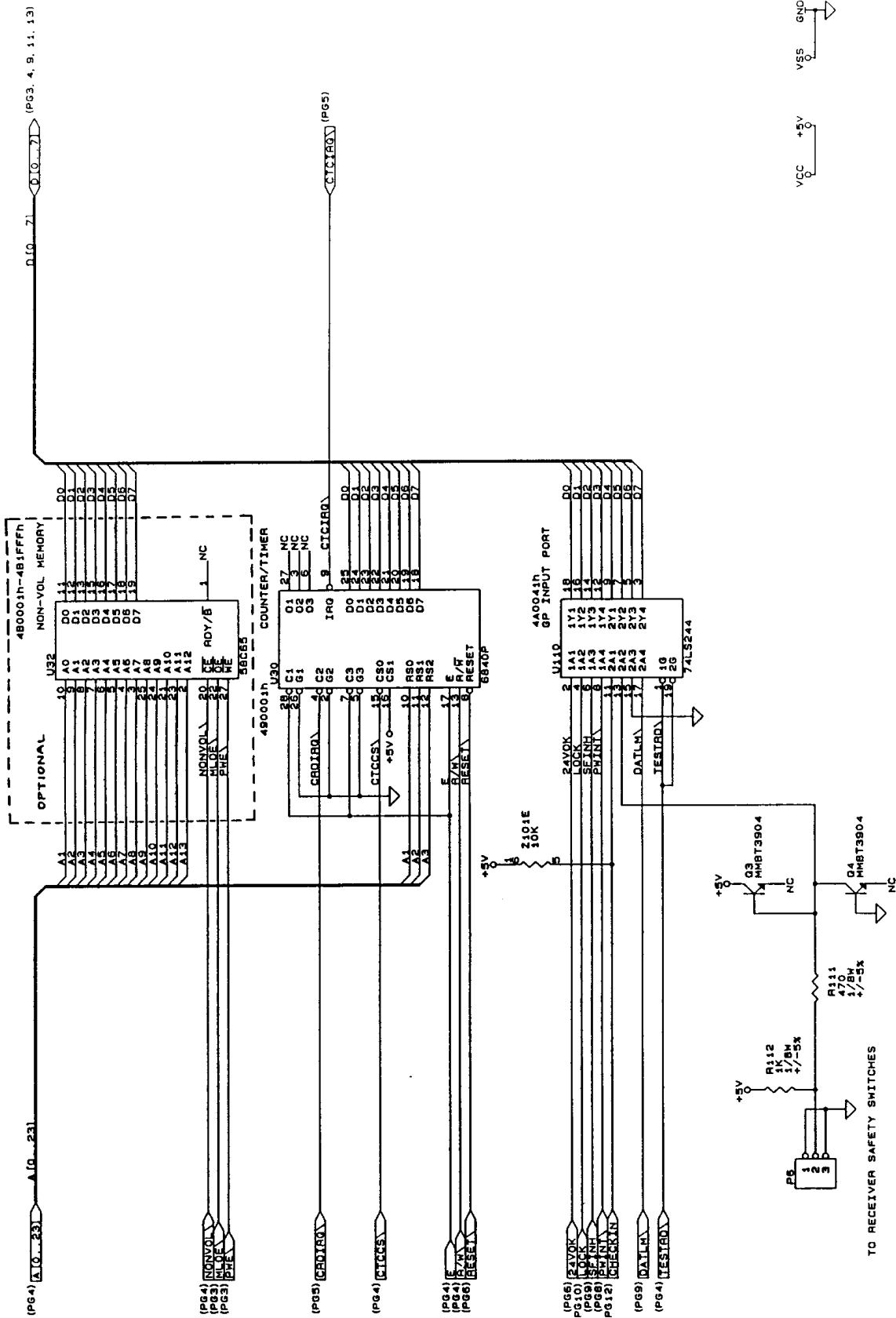

SIZE	CODE IDENT NO.	DOCUMENT NO.	REV
B	21793	4-31901-003	B
SCALE		SHEET	7 OF 13

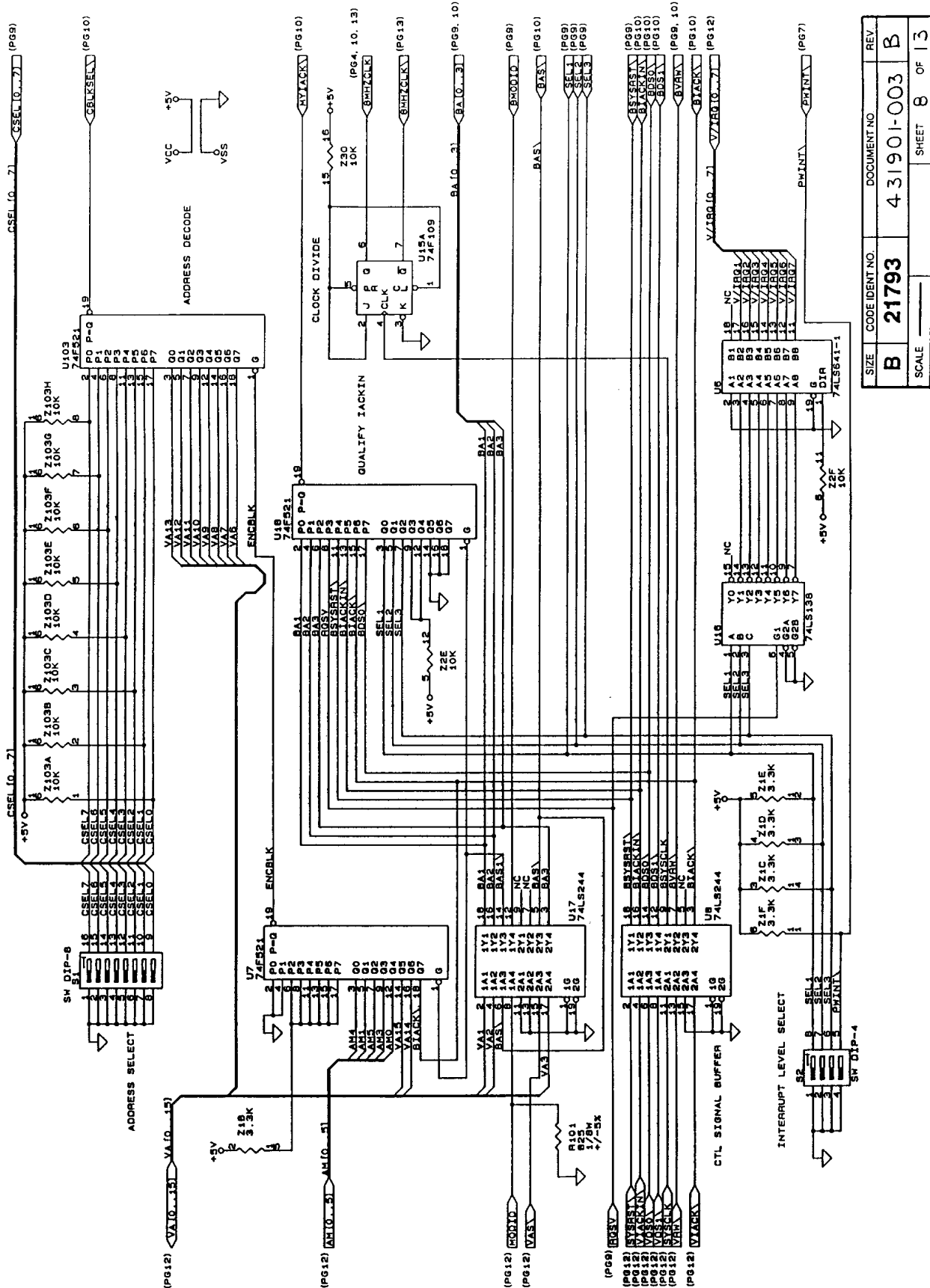

SIZE	CODE IDENT NO.	DOCUMENT NO.	REV.
B	21793	431901-003	B
SCALE		SHEET 8 OF 13	

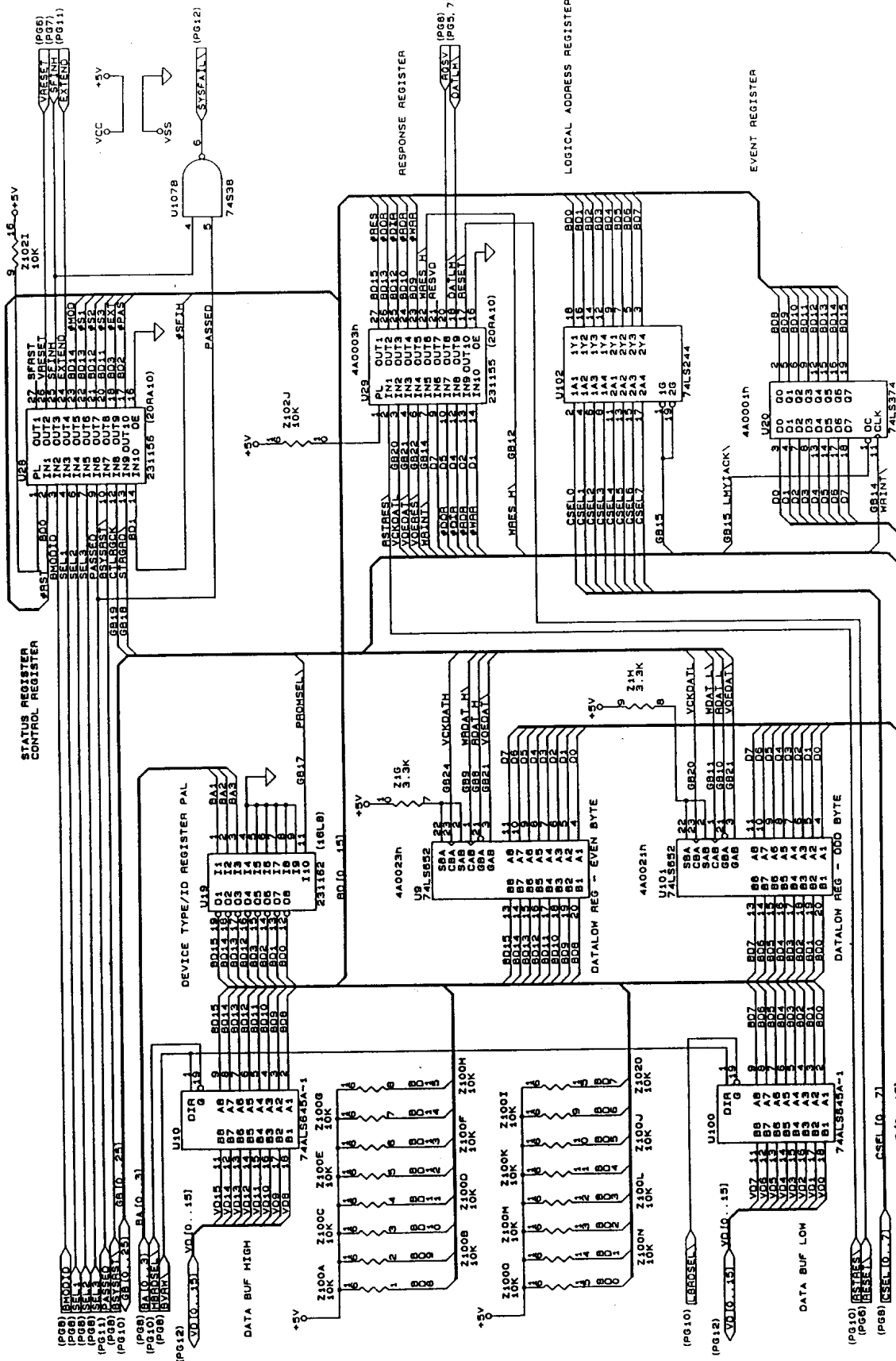

SIZE	CODE IDENT NO.	DOCUMENT NO.	REV.
B	21793	4 31901-003	8
SCALE		SHEET	9 OF 13

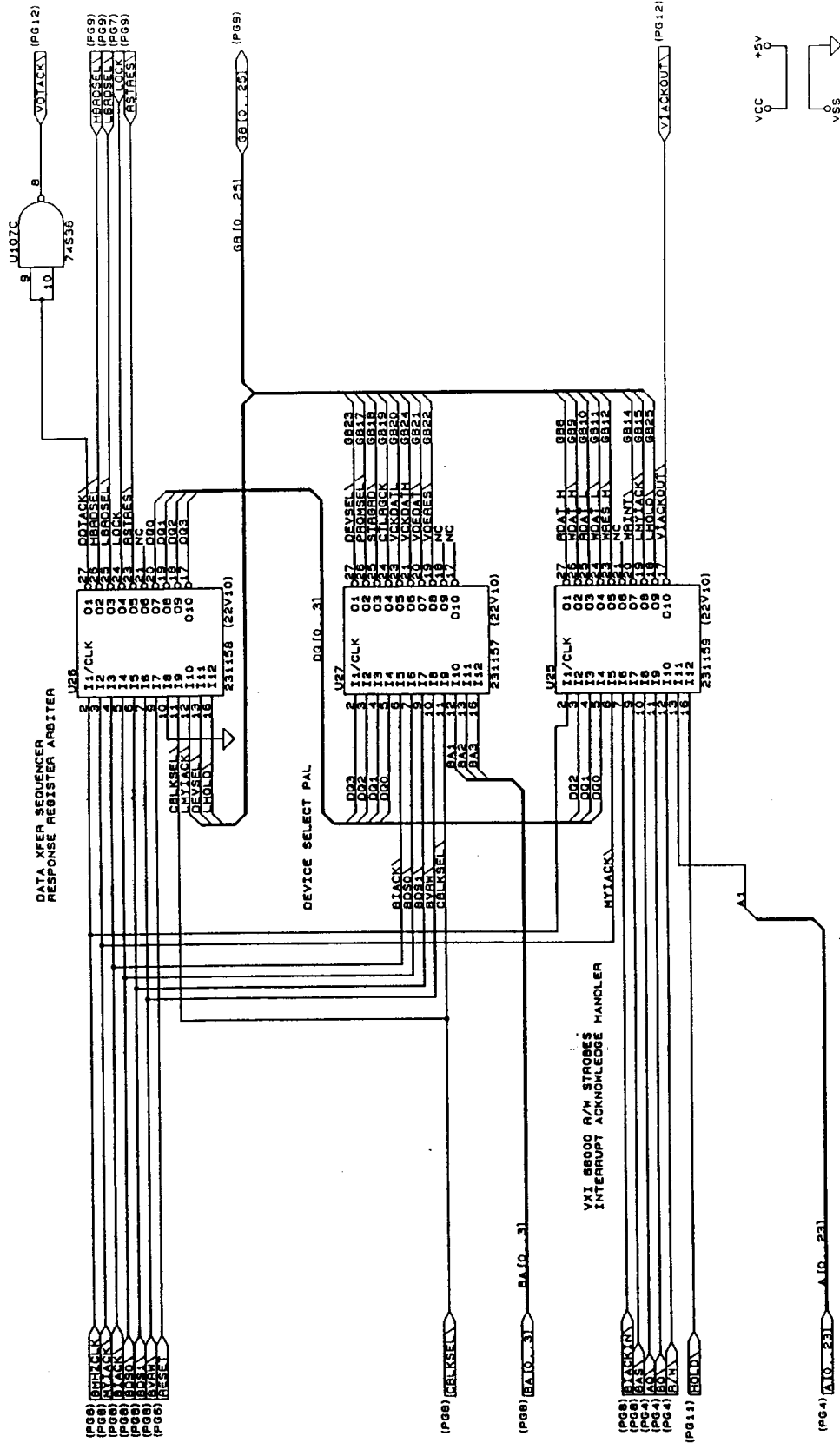

SIZE	CODE IDENT NO.	DOCUMENT NO.	REV
B	21793	431901-003	B
SCALE		SHEET 10	OF 13

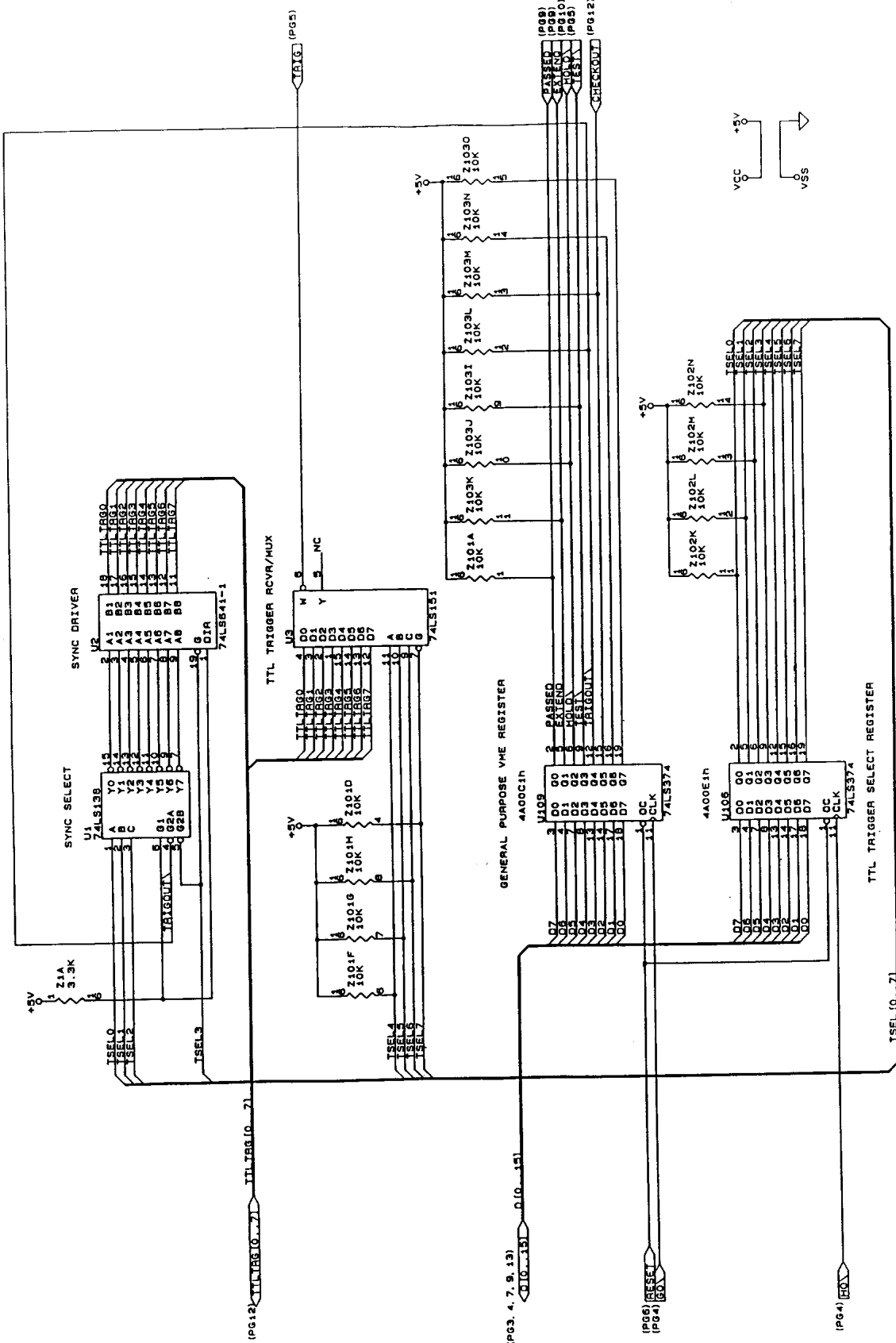

SIZE	CODE IDENT NO.	DOCUMENT NO.	REV.
B	21793	431901-003	B
SCALE		SHEET 11	OF 13

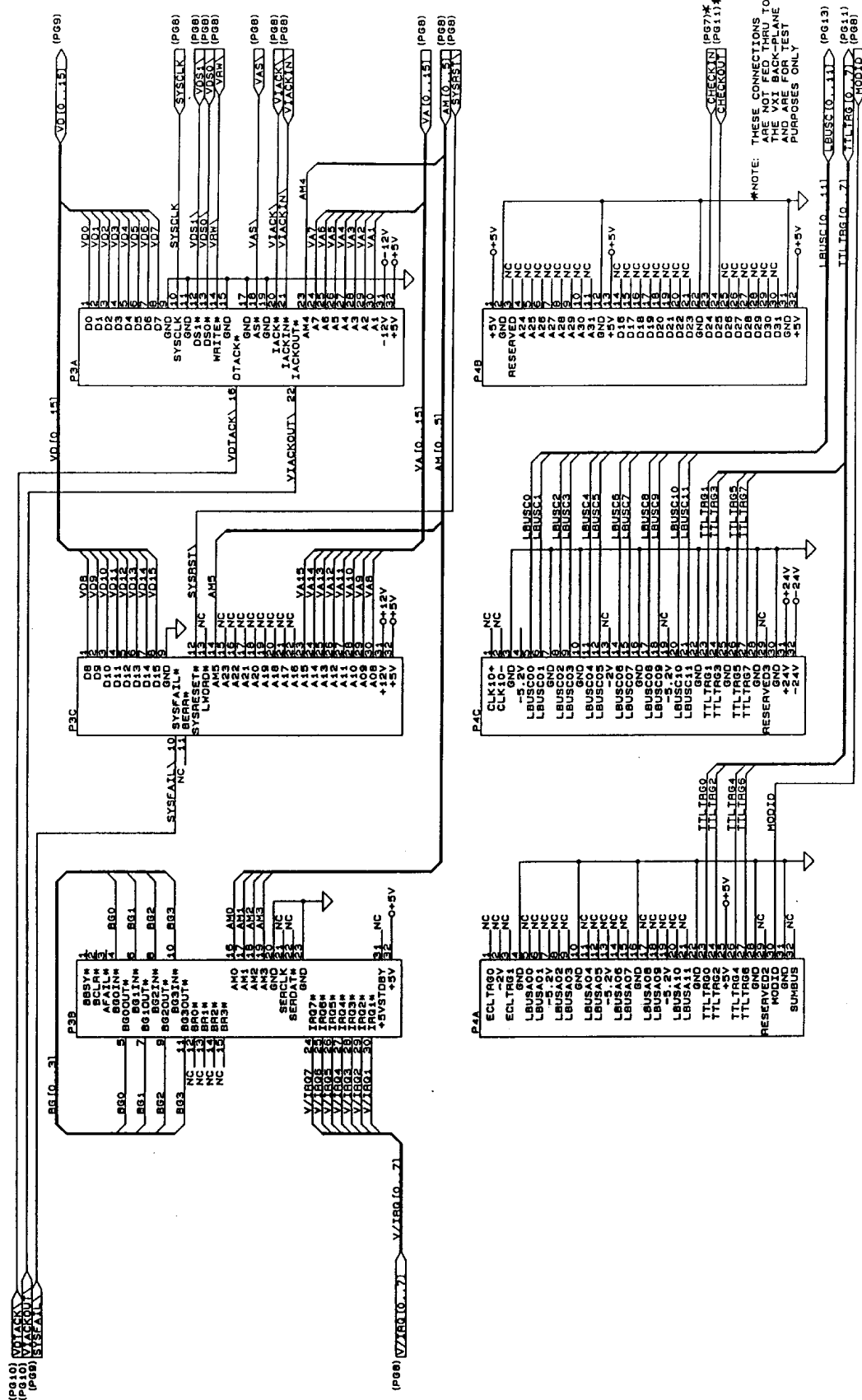

SIZE	CODE IDENT NO.	DOCUMENT NO.	REV.
B	21793	431901-003	B
SCALE		SHEET 12	OF 13

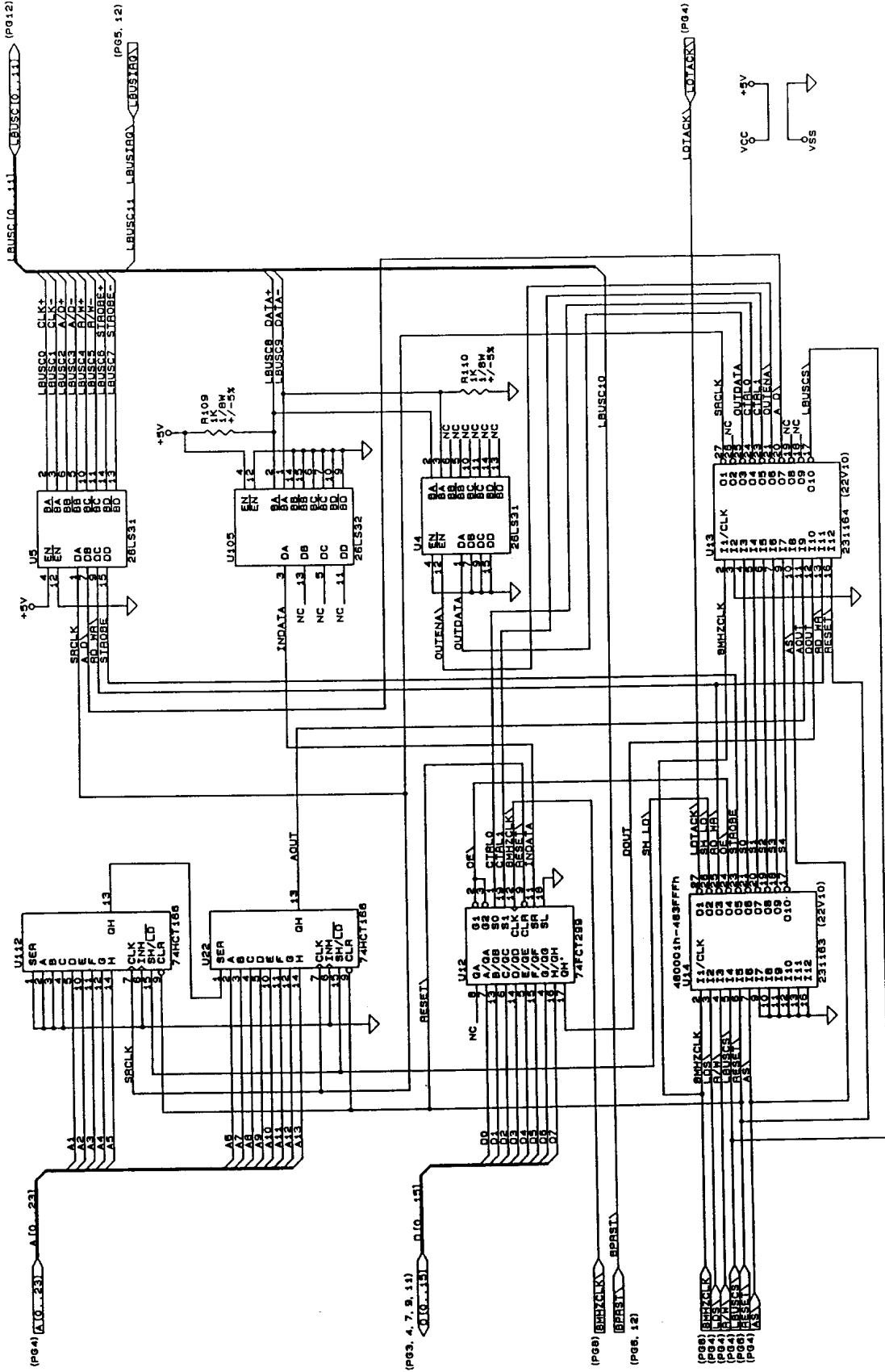

SIZE	CODE IDENT NO.	DOCUMENT NO.	REV.
B	21793	431901-003	B
SCALE		SHEET 13 OF 13	

11. CUT PIN 1 OF U32.
 10. BAG AND TAG (ITEM 80) AND SHIP WITH MODULE.
 9. ALL COMPONENTS MUST NOT EXCEED THE HEIGHT OF .375 ABOVE THE COMPONENT SIDE OF PC BOARD.
 8. INSTALL CABLE ASSY (ITEM 93) INTO P5 (ITEM 75).
 7. INSTALL STANDOFF (ITEM 92) BEFORE P5.6 (ITEM 75) FROM 100 TO 199 FOR THE CIRCUIT SIDE OF THE PCB.
 5. ITEM 79 S2, SWITCHES 1,3,4 ARE "ON" POSITION, SWITCH 2 IS "OFF" POSITION.
 4. ITEM 73 S1, SWITCHES 1,2,3,4 ARE "ON" POSITION, SWITCHES 5,6,7,8 ARE "OFF" POSITION.
 3. NOTE POSITION OF ANGLE ON SOCKET OF U31.
 2. INK STAMP SERIAL NUMBER AND CURRENT REVISION ON COMPONENT SIDE APPROX. WHERE SHOWN.
 1. REFERENCE SCHEMATIC 4-31901-005.
- NOTES: UNLESS OTHERWISE SPECIFIED

PROPRIETARY NOTICE
 THIS DOCUMENT AND THE TECHNICAL DATA HEREIN CONTAINED ARE SOLELY THE PROPERTY OF RACAL INSTRUMENTS, INC. NO PART OF THIS DOCUMENT IS TO BE REPRODUCED, COPIED, OR IN ANY MANNER DISSEMINATED WITHOUT THE WRITTEN PERMISSION OF RACAL INSTRUMENTS, INC. THIS DOCUMENT IS TO BE USED ONLY FOR THE MANUFACTURE AND MAINTENANCE OF PRODUCTS SPECIFIED IN THE INFORMATION HEREIN. IT IS NOT TO BE USED FOR ANY OTHER PURPOSES OR FOR REPRODUCTION IN ANY MANNER WITHOUT THE WRITTEN PERMISSION OF RACAL INSTRUMENTS, INC.

RACAL Instruments, Inc. 4 Goodyear St., Irvine, CA, 92718-2022			
DOCUMENT TITLE			
SMART CONTROL MODULE, 1.3			
SIZE	CODE IDENT NO.	DOCUMENT NO.	REV.
D	21793	401901-005	K
SCALE		SHEET	1 OF 4

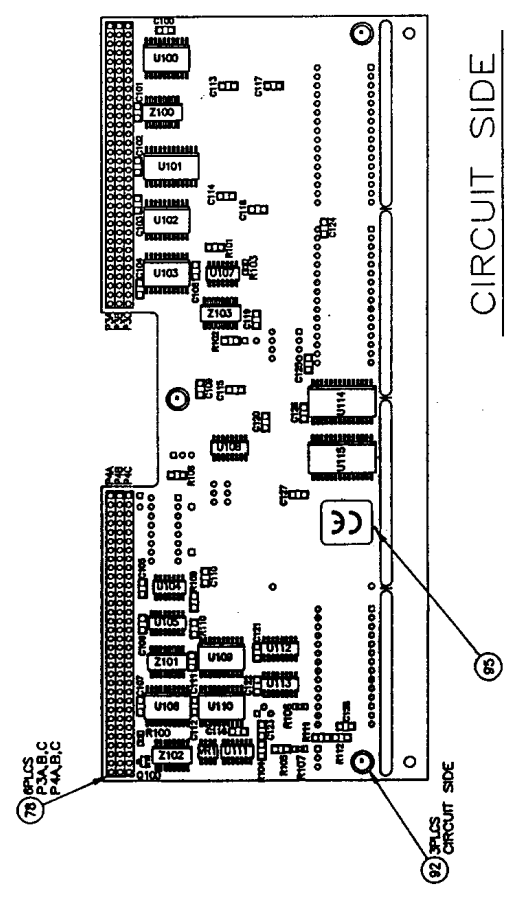
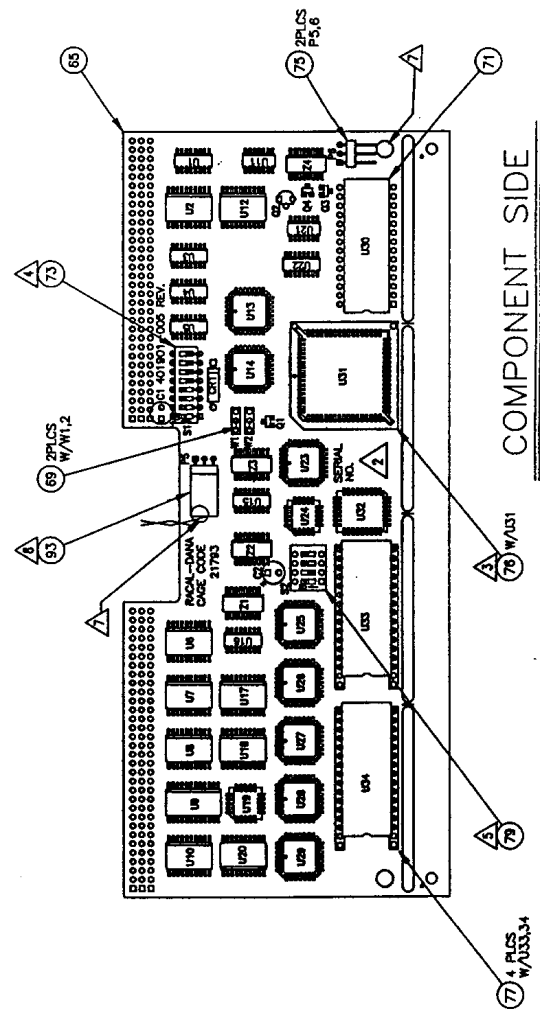

Z4, 103
M2
VR1
S2
U34, 115
R112
G4, 100
P6
CR1
C2, 128
HIGHEST REF. DES.

U114, 115	62256	28	14	U22, 112	74HCT166	16	8
U108	74LS148	16	8	U21	74HC32	14	7
U107	74S38	14	7	U20, 106, 109	74LS374	20	10
U105	26LS32	16	8	U19	231162 (16L8)	20	10
U104	74LS74	14	7	U15	74F109	16	8
U34	2314-17-002(27512)	30, 32	16	U14	231163 (22V10)	28	14
U33	2314-17-001(27512)	30, 32	16	U13	231164 (22V10)	28	14
U32	28C256/28C513	32	16	U12	74FCT299	20	10
U31	MC86000CP-B	14, 52	16, 17, 56, 57	U11, 111	LM339	3	12
U30	6840P	14	1	U10, 100	74ALS645A-1	20	10
U29	2314-08-002(20RA0)	28	15	U9, 101	74LS652	24	12
U28	231156 (20RA10)	28	15	U8, 17, 102, 110	74LS244	20	10
U27	2314-08-004(22V10)	28	14	U7, 18, 103	74F521	20	10
U26	231159 (22V10)	28	14	U4, 5	26LS31	16	8
U25	2314-08-003(22V10)	28	14	U3	74LS151	16	8
U24	2314-08-001(16LBQ)	20	10	U2, 6	74LS641-1	20	10
U23	231161 (22V10)	28	14	U1, 16, 113	74LS138	16	8
REF. DES.	IC TYPE	+5V PIN NO.	GND PIN NO.	REF. DES.	IC TYPE	+5V PIN NO.	GND PIN NO.
	IC POWER CONNECTIONS				IC POWER CONNECTIONS		

PROPRIETARY NOTICE
 THIS DOCUMENT AND THE TECHNICAL DATA HEREIN DISCLOSED ARE PROPRIETARY TO RACAL INSTRUMENTS INC. AND SHALL NOT, WITHOUT THE EXPRESS WRITTEN PERMISSION OF RACAL INSTRUMENTS INC. BE REPRODUCED, COPIED, OR USED IN ANY MANNER OR FOR ANY PURPOSES, INCLUDING REPRODUCTION, TRANSMISSION, OR DISTRIBUTION FROM A COMPETITIVE SOURCE OR USED FOR MANUFACTURE BY ANYONE OTHER THAN RACAL INSTRUMENTS INC. THE INFORMATION HEREON HAS BEEN DEVELOPED FOR THE PURPOSES OF ENGINEERING EVALUATION AND FOR INCORPORATION INTO TECHNICAL SPECIFICATIONS AND OTHER DOCUMENTS WHICH SPECIFY THE REQUIREMENT OF PRODUCTS FROM RACAL INSTRUMENTS INC.

Racal Instruments, Inc.			
4 Goodyear St., Irvine, CA. 92718-2002			
DOCUMENT TITLE			
SCHEM., 1260 CPU, 1.3			
SIZE	CODE IDENT. NO.	DOCUMENT NO.	REV
B	21793	4-31901-005	C
SCALE		SHEET	OF 13

- ▲ PAL U27 PIN 18 HAS A PIN NAMED RESVD. THIS PIN IS CONNECTED INTERNALLY IN PAL.
 4. REFERENCE DESIGNATORS RANGE FROM 1 TO 88 FOR THE COMPONENT SIDE AND FROM 100 TO 199 FOR THE SOLDER SIDE OF THE PCB.
 3. RESISTOR VALUES ARE IN OHMS.
 2. CAPACITOR VALUES ARE IN MICROFARADS, +/-20%, 50V UNLESS OTHERWISE SPECIFIED.
 1. RESISTOR NETWORKS ARE IN OHMS, +/-2%.
- NOTES: UNLESS OTHERWISE SPECIFIED

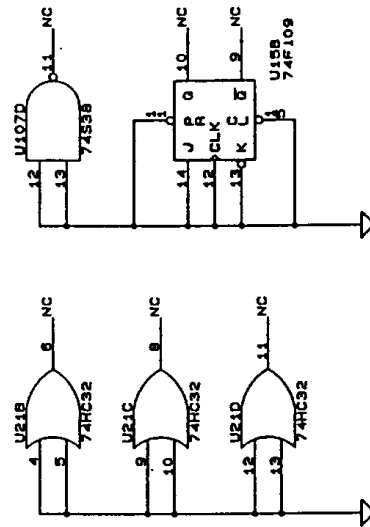
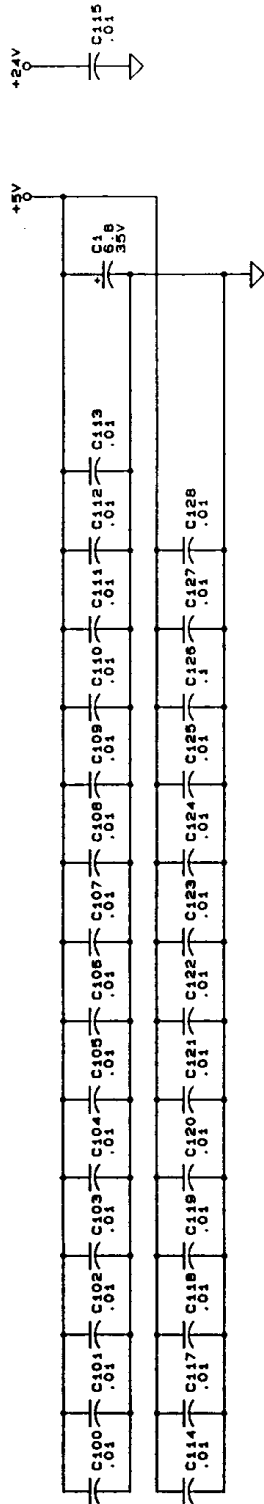

SIZE	CODE IDENT NO.	DOCUMENT NO.	REV.
B	21793	431901-005	C
SCALE		SHEET 2	OF 13

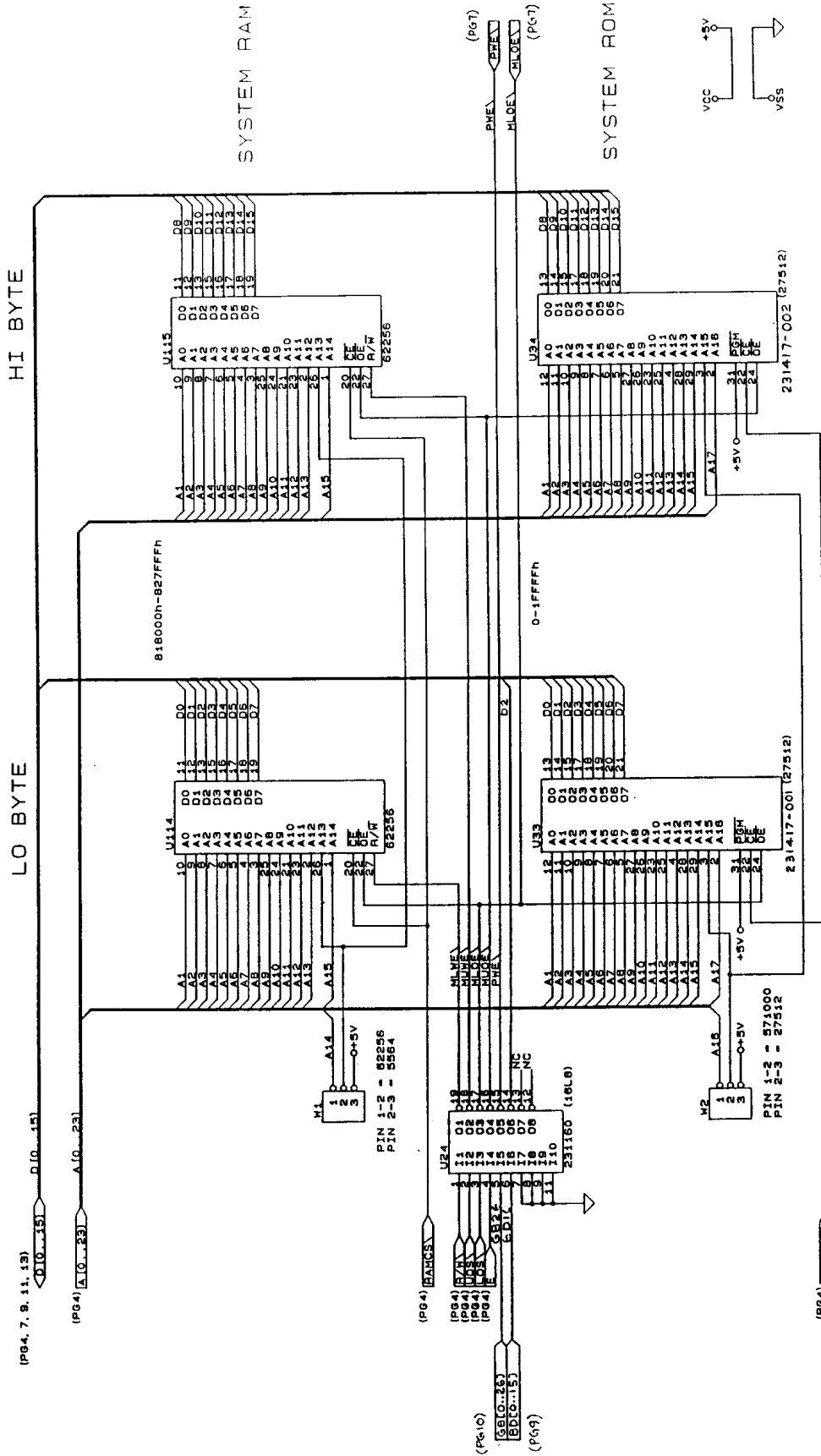

SIZE	CODE IDENT NO.	DOCUMENT NO.	REV
B	21793	431901-005	C
SCALE		SHEET 3 OF 13	

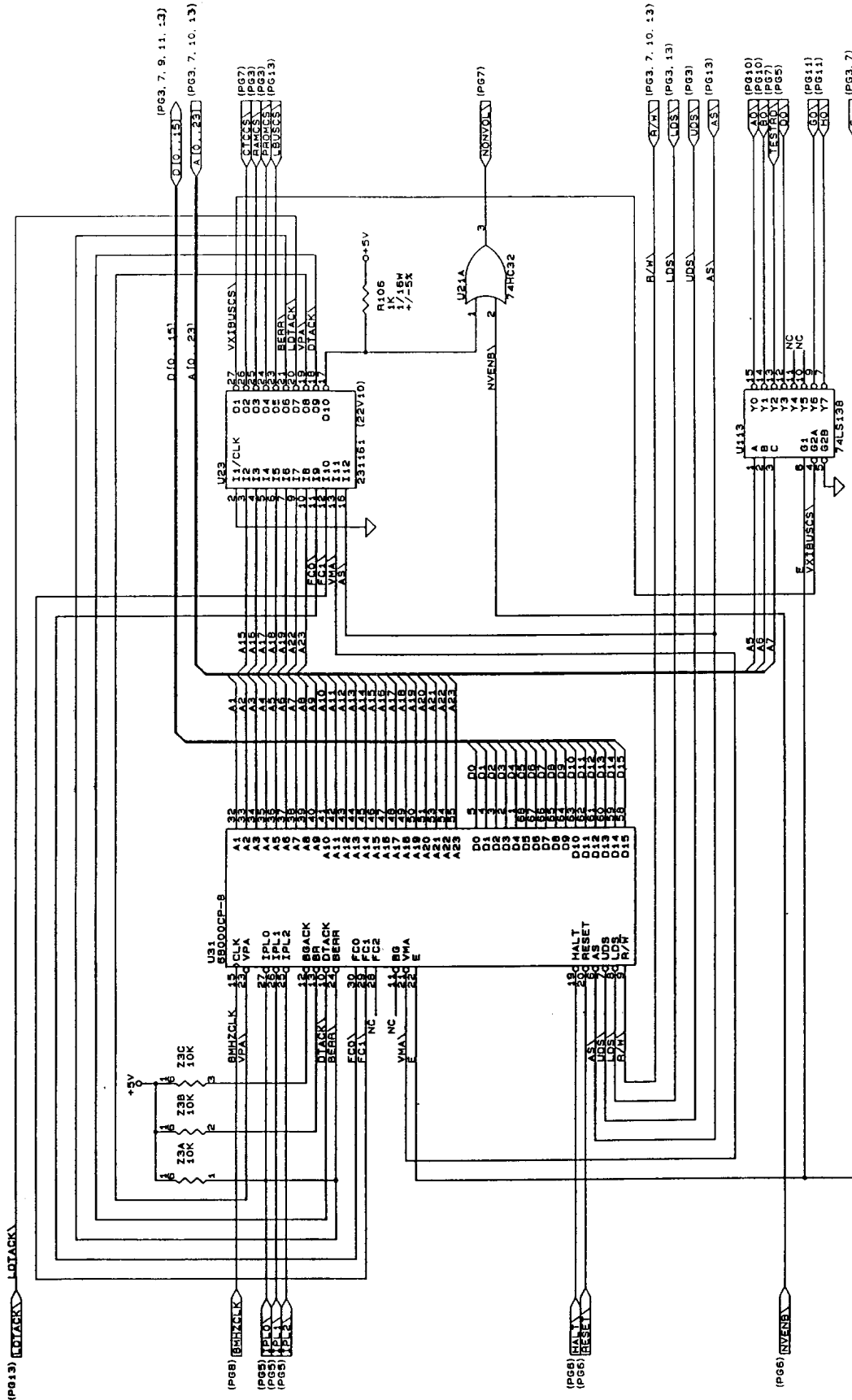

SIZE	CODE IDENT NO.	DOCUMENT NO.	REV.
B	21793	431901-005	C
SCALE		SHEET 4	OF 13

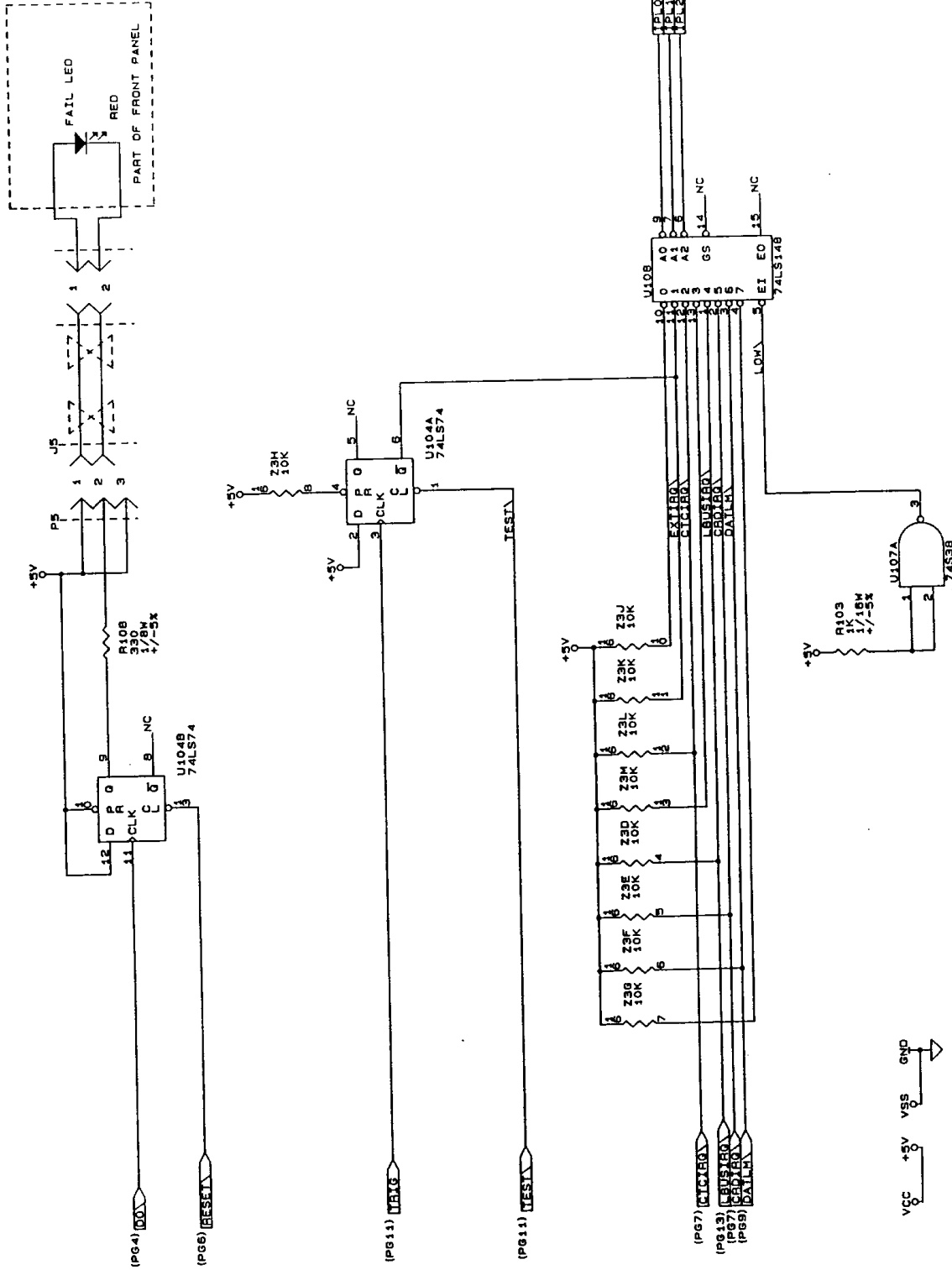

SIZE	CODE IDENT NO.	DOCUMENT NO.	REV.
B	21793	4 31901-005	C
SCALE		SHEET 5	OF 13

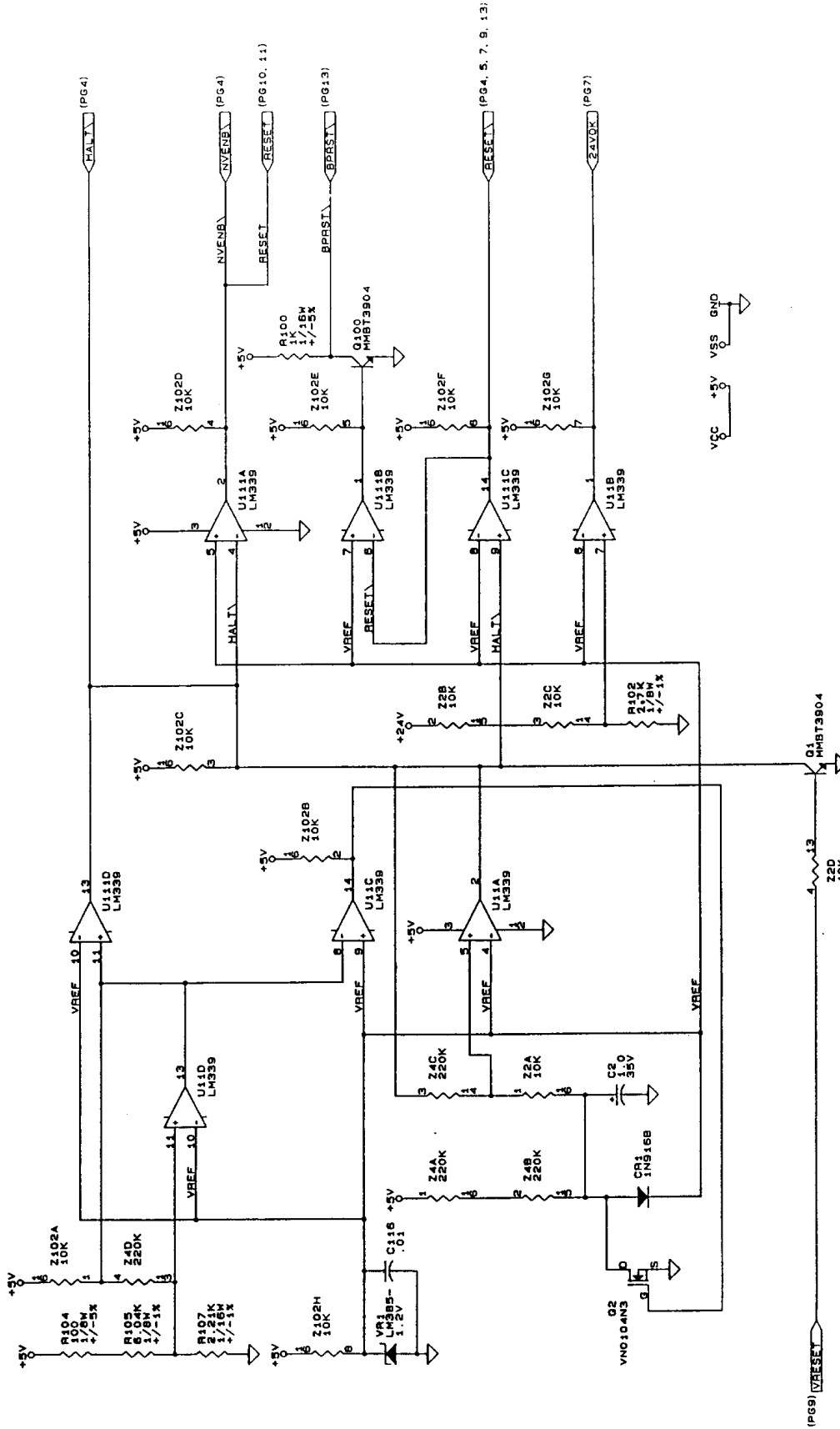

SIZE	CODE IDENT NO.	DOCUMENT NO.	REV
B	21793	431901-005	C
SCALE		SHEET 6	OF 13

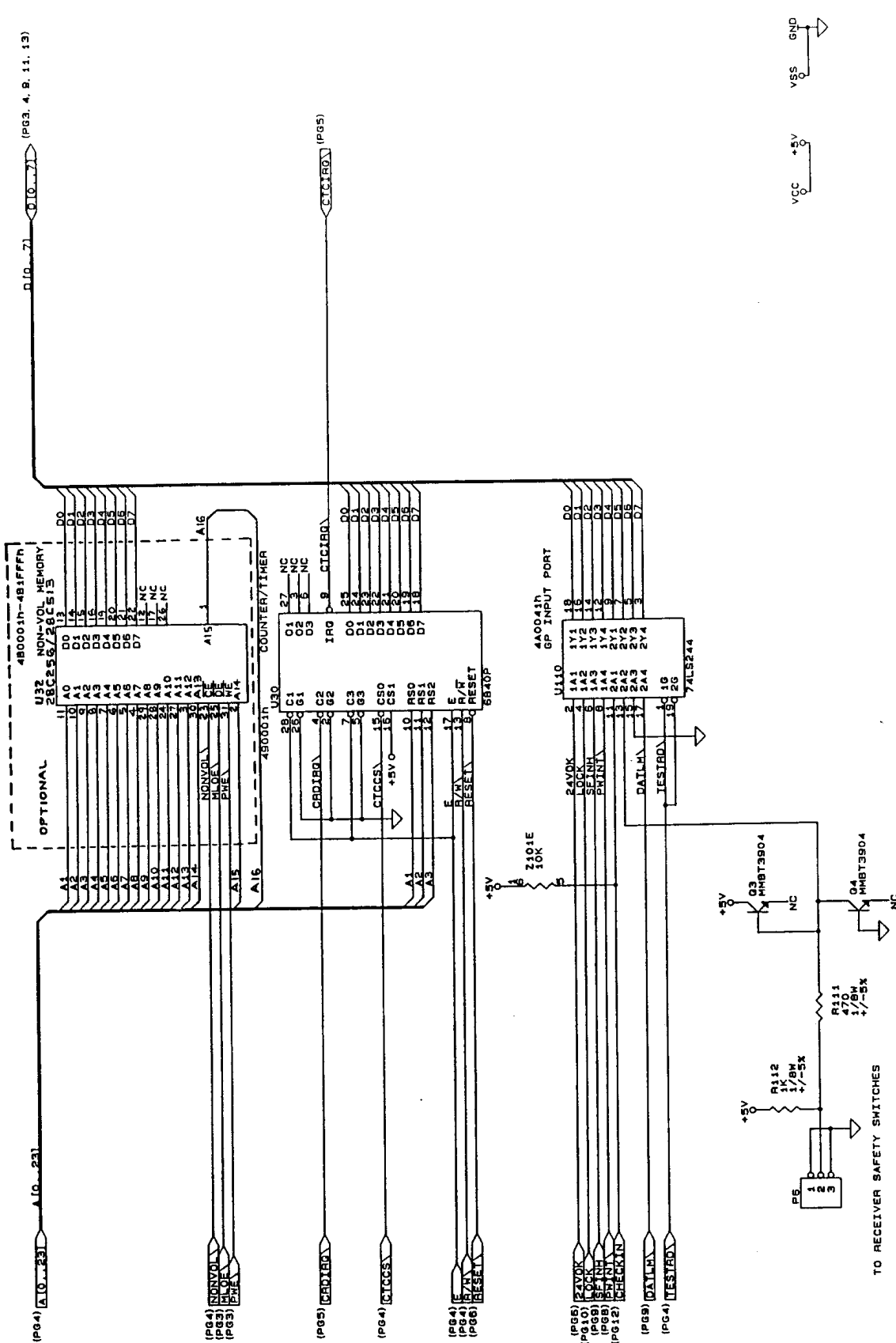

SIZE	CODE IDENT NO.	DOCUMENT NO.	REV.
B	21793	431901-005	C
SCALE		SHEET	7 OF 13

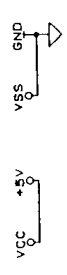

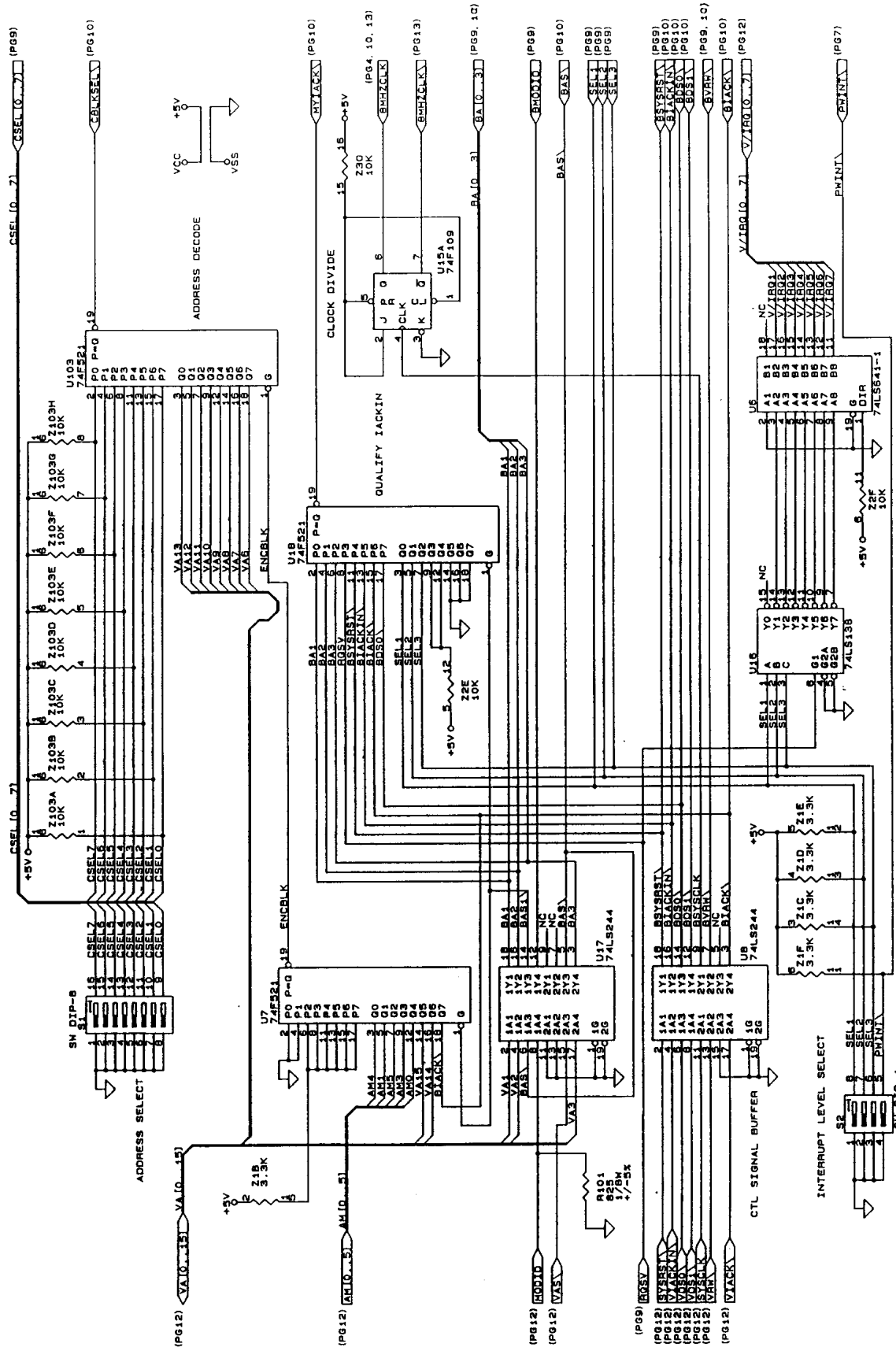

SIZE	CODE IDENT NO.	DOCUMENT NO.	REV
B	21793	431901-005	C
SCALE		SHEET 8	OF 13

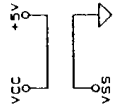
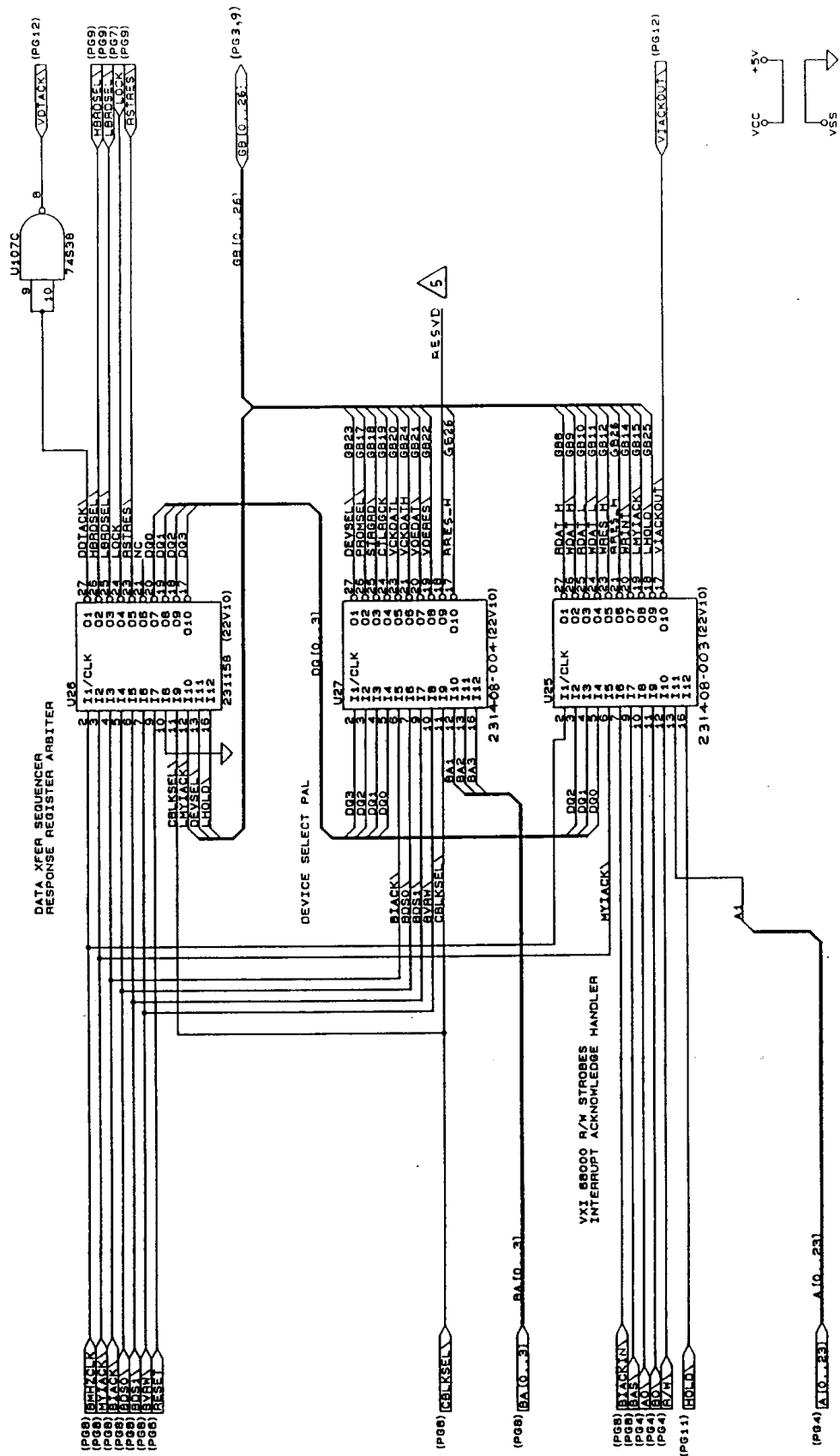

SIZE	CODE IDENT NO.	DOCUMENT NO.	REV
B	21793	431901-005	C
SCALE		SHEET 10	OF 13

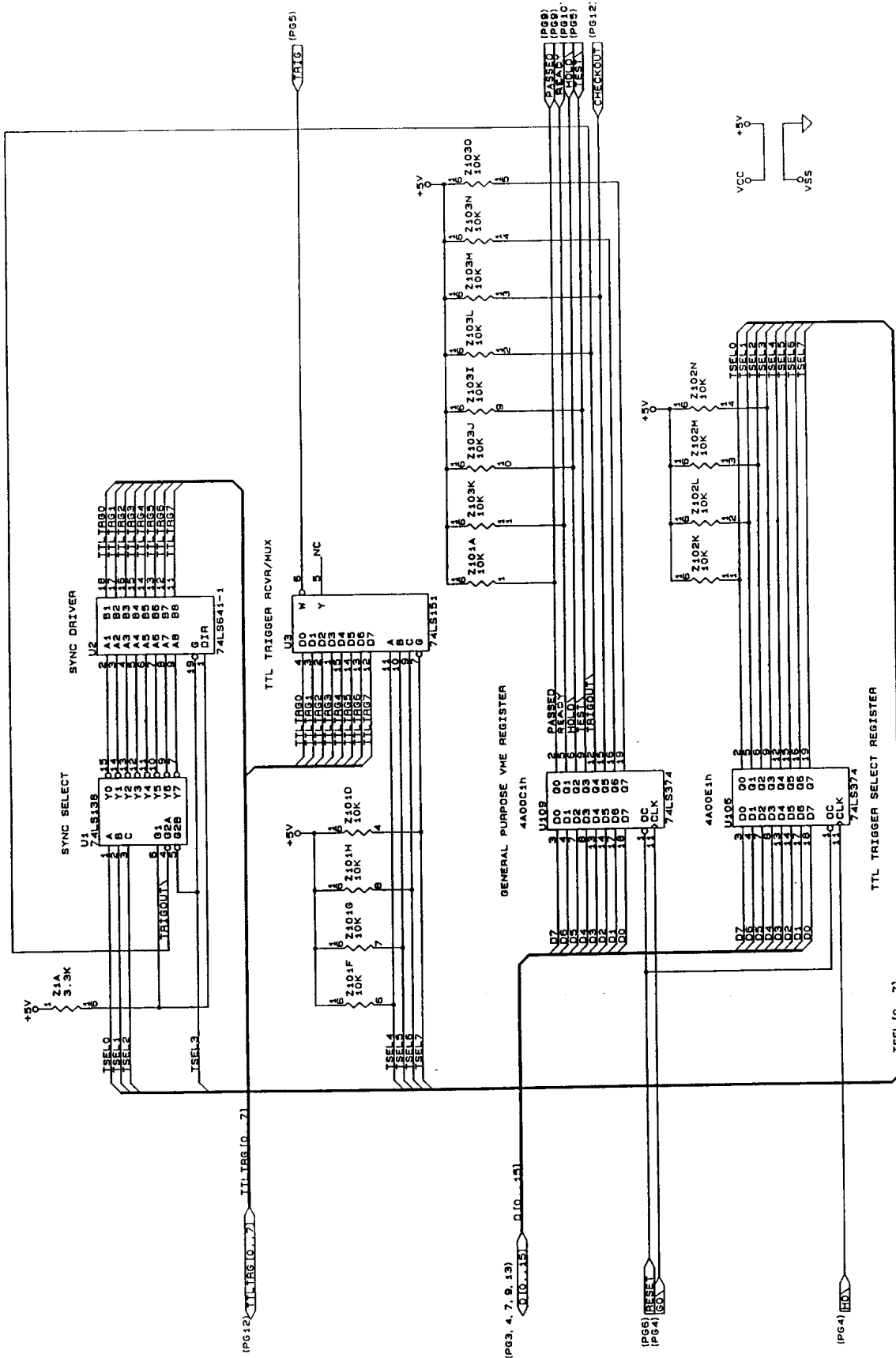

SIZE	CODE IDENT NO.	DOCUMENT NO.	REV.
B	21793	431901-005	C
SCALE		SHEET	OF
		11	13

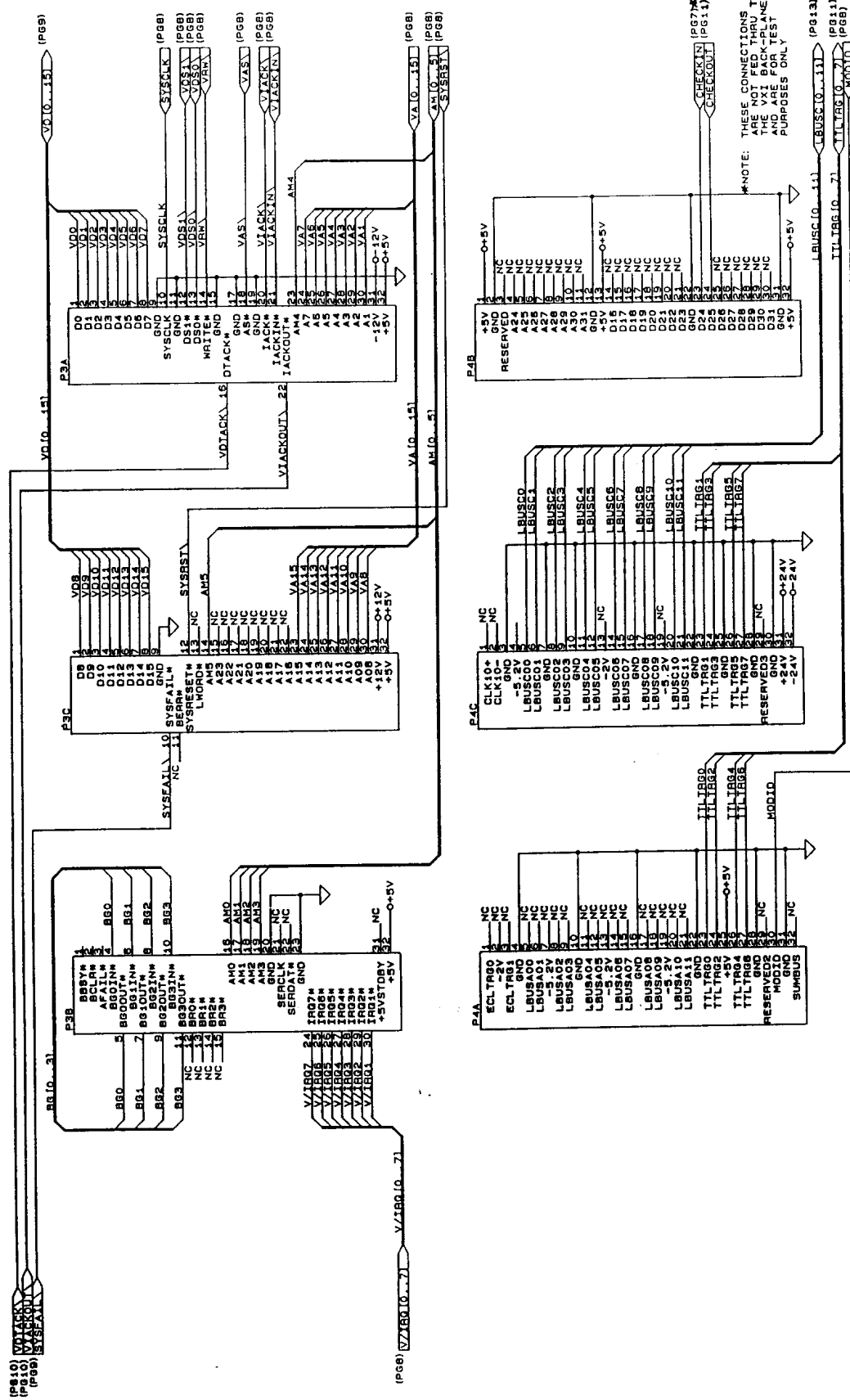

SIZE	CODE IDENT NO.	DOCUMENT NO.	REV.
B	21793	431901-005	C
SCALE		SHEET 12	OF 13

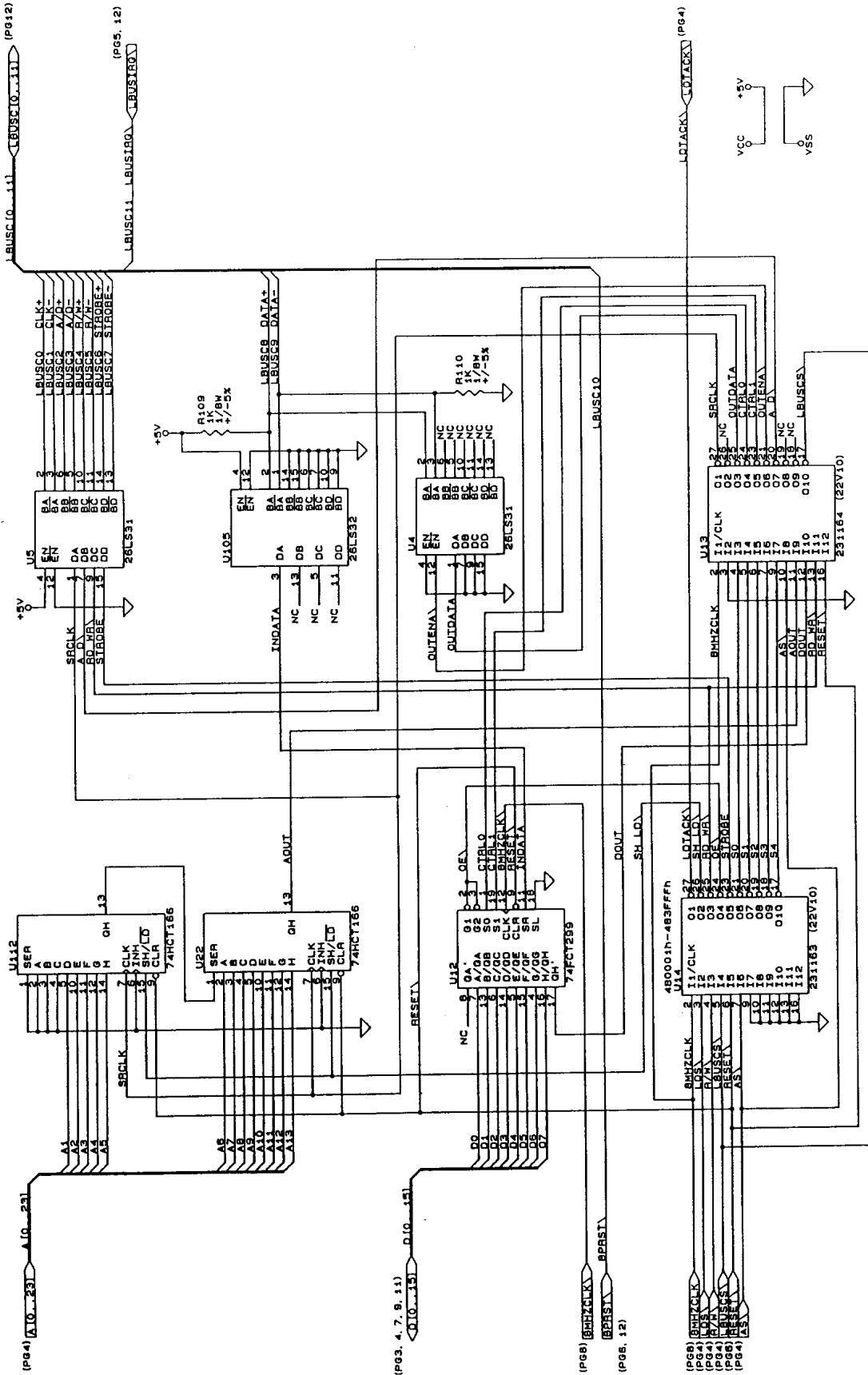

SIZE	CODE IDENT NO.	DOCUMENT NO.	REV
B	21793	431901-005	C
SCALE		SHEET 13 OF 13	

This page was left intentionally blank.

Chapter 6

Parts Lists

401951	PCB Assy, L-Bus Jumper, P4.....	6-2
401951-003	PCB Assy, L-Bus Jumper, P3.....	6-2
401901	PCB Assy, 1260 Master CPU	6-3
401901-001	PCB Assy, 1260 Master CPU	6-5
401901-005	PCB Assy, 1260 Master CPU	6-7
	List of Suppliers.....	6-9

401951 - PCB ASSY., L-BUS JUMPER, P4 (REV. E)

REF DESIG	RACAL INST P/N	DESCRIPTION	FSC	MANUFACTURER'S P/N
R1	000221	RES, CARBON, 220 OHM, 1/4W, 5 PCT	81349	RC07GF220J
{1}1	411951	PCB, L-BUS JUMPER (UNLOADED)	21793	411951
{3}2	601858-032	CONNECTOR, PCB, PLUG, 32 PIN	52072	CAS32MPF1B

401951-003 - PCB ASSY., BUS GRANT JUMPER, P3

REF DESIG	RACAL INST P/N	DESCRIPTION	FSC	MANUFACTURER'S P/N
{1}1	411951	PCB, L-BUS JUMPER (UNLOADED)	21793	411951
{3}2	601858-032	CONNECTOR, PCB, PLUG, 32 PIN	52072	CAS32MPF1B
{5}A/R	500204	WIRE, TEFLON, SOLID, 28 GA, WHT	04946	1100-32-C-9

1260 Series User Manual

401901 PCB ASSY., 1260 MASTER CPU (OPT. 01)

REF DESIG	RACAL INST P/N	DESCRIPTION	FSC	MANUFACTURER'S P/N
C1	110126	CAP, TANTA, 6.8UF, 35V, 20 PERCENT	05397	T355F685M035AS
C2	110143	CAP, TANTA, 1 UF, 35V, 20 PERCENT	05397	T355A105M035AS
C100-C128	R-21-1801	CAP, CHIP, 10 NF	95275	VJ1206Y103MF
CR1	211083	DIODE, SILICON	81349	1N916B
P3A	601858-032	CONNECTOR, PCB, PLUG, 32 PIN	52072	CAS32MPF1B
P3B	601858-032	CONNECTOR, PCB, PLUG, 32 PIN	52072	CAS32MPF1B
P3C	601858-032	CONNECTOR, PCB, PLUG, 32 PIN	52072	CAS32MPF1B
P4A	601858-032	CONNECTOR, PCB, PLUG, 32 PIN	52072	CAS32MPF1B
P4B	601858-032	CONNECTOR, PCB, PLUG, 32 PIN	52072	CAS32MPF1B
P4C	601858-032	CONNECTOR, PCB, PLUG, 32 PIN	52072	CAS32MPF1B
P5	601710-003	CONNECTOR, RT.ANGLE, SINGLE ROW, 3P	52072	CA-S03R-23B09
P6	601710-003	CONNECTOR, RT.ANGLE, SINGLE ROW, 3P	52072	CA-S03R-23B09
Q1	200320	TRANSISTOR, NPN	04713	MMBT3904
Q2	200295	TRANSISTOR, N-CHAN, MOSFET	17856	VN10KM
Q3	200320	TRANSISTOR, NPN	04713	MMBT3904
Q4	200320	TRANSISTOR, NPN	04713	MMBT3904
Q100	200320	TRANSISTOR, NPN	04713	MMBT3904
R100	050000-102	RES, CHIP, 1K, .06W, 5PCT	91637	CRCW-0805SERIES
R101	050038	RES, CHIP, 825 OHM, 1/8W, 5PCT	65940	MCR18825J
R102	R-20-5766	RES, CHIP, 2.7K, 1/8W, 5 PCT	65940	MCR18-2.7K OHM-5 PCT
R103	050000-102	RES, CHIP, 1K, .06W, 5PCT	91637	CRCW-0805SERIES
R104	R-20-5764	RES, CHIP, 100 OHM, 1/8W, 5 PCT	65940	MCR18-100 OHM-5 PCT
R105	050040	RES, CHIP, 6.04K, 1/8W, 1PCT	65940	MCR186.04KFW
R106	050000-102	RES, CHIP, 1K, .06W, 5PCT	91637	CRCW-0805SERIES
R107	050047	RES, CHIP, 2.21K, .06W, 1PCT	56235	50705CPX2211F30
R108	R-20-5787	RES, CHIP, 330 OHM, 1/8W, 5 PCT, 200V	65940	MCR18-330 OHM-5 PCT
R109	R-20-5792	RES, CHIP, 1K, 1/8W, 5 PCT, 200V	65940	MCR18-1K-5 PCT
R110	R-20-5792	RES, CHIP, 1K, 1/8W, 5 PCT, 200V	65940	MCR18-1K-5 PCT
R111	R-20-5765	RES, CHIP, 470 OHM, 1/8W, 5 PCT	65940	MCR18-470 OHM-5 PCT
R112	R-20-5792	RES, CHIP, 1K, 1/8W, 5 PCT, 200V	65940	MCR18-1K-5 PCT
S1	601699	SWITCH, DIP, 8 POS, LOW PROFILE	71450	207-8-LPST
S2	601859	SWITCH, DIP, 4 POS	11237	2074LPST
U1	231094	IC, DEMUX DECODER	18324	N74LS138D
U2	231122	IC, SOIC	01295	SN74LS641-1DW
U3	231123	IC, MULTIPLEXER	18324	74LS151D
U4	231125	IC, DIGITAL, LINE DRIVER	27014	DS26LS31MN
U5	231125	IC, DIGITAL, LINE DRIVER	27014	DS26LS31MN
U6	231122	IC, SOIC	01295	SN74LS641-1DW
U7	230986	IC, 8-BIT COMPARATOR	07263	74F521SC
U8	231092	IC, TRI-STATE BUFFER	18324	74LS244D
U9	231118	IC, DIGITAL BUFFER	01295	SN74LS652DW
U10	231129	IC, OCTAL BUS TRANSCEIVERS	18324	N74LS645-1D
U11	231093	IC, QUAD COMPARATOR	04713	LM339D
U12	231500	IC, 8-INPUT SHIFT REGISTER	18324	N74F299D
U13	231164	IC, MEMORY	21793	231164
U14	231163	IC, MEMORY	21793	231163
U15	230980	IC, DUAL JK POS EDGE-TRIG F-F	07263	74F109SC
U16	231094	IC, DEMUX DECODER	18324	N74LS138D
U17	231092	IC, TRI-STATE BUFFER	18324	74LS244D
U18	230986	IC, 8-BIT COMPARATOR	07263	74F521SC
U19	231162	IC, MEMORY	21793	231162
U20	231124	IC, FLIP-FLOP	18324	N74LS374D
U21	231121	IC, QUADRUPLE 2-INPUT POS-OR GATE	01295	SN74HC32D
U22	231120	IC, 8-BIT, PARALLEL/SERIAL OUT S.R.	18324	74HCT166D
U23	231161	IC, MEMORY	21793	231161
U24	231160	IC, MEMORY	21793	231160
U25	231159	IC, MEMORY	21793	231159
U26	231158	IC, MEMORY	21793	231158
U27	231157	IC, MEMORY	21793	231157

401901 PCB ASSY., 1260 MASTER CPU

REF DESIG	RACAL INST P/N	DESCRIPTION	FSC	MANUFACTURER'S P/N
U28	231156	IC, MEMORY	21793	231156
U29	231155	IC, MEMORY	21793	231155
U30	230780	IC, COUNTER TIMER	04713	MC6840P
U31	231136	IC, MICROPROCESSING UNIT	62786	HD68000CP-8
U32	231146	IC, MEMORY, EEPROM	21793	231146
U33	231166	IC, MEMORY	21793	231166
U34	231167	IC, MEMORY	21793	231167
U100	231129	IC, OCTAL BUS TRANSCEIVERS	18324	N74LS645-1D
U101	231118	IC, DIGITAL BUFFER	01295	SN74LS652DW
U102	231092	IC, TRI-STATE BUFFER	18324	74LS244D
U103	230986	IC, 8-BIT COMPARATOR	07263	74F521SC
U104	231127	IC, FLIP-FLOP	04713	SN74LS74AD
U105	231096	IC, QUAD DIFF RECEIVER	01295	AM26LS32ACD
U106	231124	IC, FLIP-FLOP	18324	N74LS374D
U107	231126	IC, NAND GATE	18324	74S38D
U108	231128	IC, ENCODER	01295	SN74LS148D
U109	231124	IC, FLIP-FLOP	18324	N74LS374D
U110	231092	IC, TRI-STATE BUFFER	18324	74LS244D
U111	231093	IC, QUAD COMPARATOR	04713	LM339D
U112	231120	IC, 8-BIT, PARALLEL/SERIAL OUT S.R.	18324	74HCT166D
U113	231094	IC, DEMUX DECODER	18324	N74LS138D
U114	231137	IC, MEMORY	21793	231137
U115	231137	IC, MEMORY	21793	231137
VR1	230951	IC, 1.2V MICRO PWR V REF DIODE	27014	LM385BM-1.2
Z1	080121	RES NETWORK, 3.3K, 16P, 8R	11236	767-163R33KS
Z2	080116	RES NETWORK, 16P8R, 10K	73138	628-AL-103J
Z3	080120	RES NETWORK, 10K	11236	767-161R10K
Z4	080119	RES NETWORK, 220K	91637	SOMC-1603-224K
Z100	080120	RES NETWORK, 10K	11236	767-161R10K
Z101	080120	RES NETWORK, 10K	11236	767-161R10K
Z102	080120	RES NETWORK, 10K	11236	767-161R10K
Z103	080120	RES NETWORK, 10K	11236	767-161R10K
{65}1	411901	PCB OPTION 01 (UNLOADED)	21793	411901
{69}A/R	500022	WIRE, BARE COPPER/TIN, 22 GA	21793	500022
{71}1	601277	IC SOCKET, 28-PIN	06776	ICA-286-S-TG
{76}1	601715	SOCKET, CHIP CARRIER, 68 PIN	09922	Q1LE68P-410T
{77}4	601735-016	CONNECTOR, PCB, RECEPT, 16 PIN	55322	SL116G32
{92}3	610257	STANDOFF, SWAGE, 1/4D, 4-40 X .31	06540	9534BB04403A
{93}1	404782	CABLE ASSY., LED FAIL	21793	404782

1260 Series User Manual

401901-003 PCB ASSY., 1260 MASTER CPU

REF DESIG	RACAL INST P/N	DESCRIPTION	FSC	MANUFACTURER'S P/N
C1	110126	CAP, TANTA, 6.8UF, 35V, 20 PERCENT	05397	T355F685M035AS
C2	110143	CAP, TANTA, 1 UF, 35V, 20 PERCENT	05397	T355A105M035AS
C100-C128	R-21-1801	CAP, CHIP, 10 NF	95275	VJ1206Y103MF
CR1	211083	DIODE, SILICON	81349	1N916B
P3A	601858-032	CONNECTOR, PCB, PLUG, 32 PIN	52072	CAS32MPF1B
P3B	601858-032	CONNECTOR, PCB, PLUG, 32 PIN	52072	CAS32MPF1B
P3C	601858-032	CONNECTOR, PCB, PLUG, 32 PIN	52072	CAS32MPF1B
P4A	601858-032	CONNECTOR, PCB, PLUG, 32 PIN	52072	CAS32MPF1B
P4B	601858-032	CONNECTOR, PCB, PLUG, 32 PIN	52072	CAS32MPF1B
P4C	601858-032	CONNECTOR, PCB, PLUG, 32 PIN	52072	CAS32MPF1B
P5	601710-003	CONNECTOR, RT.ANGLE, SINGLE ROW, 3P	52072	CA-S03R-23B09
P6	601710-003	CONNECTOR, RT.ANGLE, SINGLE ROW, 3P	52072	CA-S03R-23B09
Q1	200320	TRANSISTOR, NPN	04713	MMBT3904
Q2	200295	TRANSISTOR, N-CHAN, MOSFET	17856	VN10KM
Q3	200320	TRANSISTOR, NPN	04713	MMBT3904
Q4	200320	TRANSISTOR, NPN	04713	MMBT3904
Q100	200320	TRANSISTOR, NPN	04713	MMBT3904
R100	050000-102	RES, CHIP, 1K, .06W, 5PCT	91637	CRCW-0805SERIES
R101	050038	RES, CHIP, 825 OHM, 1/8W, 5PCT	65940	MCR18825J
R102	R-20-5766	RES, CHIP, 2.7K, 1/8W, 5 PCT	65940	MCR18-2.7K OHM-5 PCT
R103	050000-102	RES, CHIP, 1K, .06W, 5PCT	91637	CRCW-0805SERIES
R104	R-20-5764	RES, CHIP, 100 OHM, 1/8W, 5 PCT	65940	MCR18-100 OHM-5 PCT
R105	050040	RES, CHIP, 6.04K, 1/8W, 1PCT	65940	MCR186.04KFW
R106	050000-102	RES, CHIP, 1K, .06W, 5PCT	91637	CRCW-0805SERIES
R107	050047	RES, CHIP, 2.21K, .06W, 1PCT	56235	50705CPX2211F30
R108	R-20-5787	RES, CHIP, 330 OHM, 1/8W, 5 PCT, 200V	65940	MCR18-330 OHM-5 PCT
R109	R-20-5792	RES, CHIP, 1K, 1/8W, 5 PCT, 200V	65940	MCR18-1K-5 PCT
R110	R-20-5792	RES, CHIP, 1K, 1/8W, 5 PCT, 200V	65940	MCR18-1K-5 PCT
R111	R-20-5765	RES, CHIP, 470 OHM, 1/8W, 5 PCT	65940	MCR18-470 OHM-5 PCT
R112	R-20-5792	RES, CHIP, 1K, 1/8W, 5 PCT, 200V	65940	MCR18-1K-5 PCT
S1	601699	SWITCH, DIP, 8 POS, LOW PROFILE	71450	207-8-LPST
S2	601859	SWITCH, DIP, 4 POS	11237	2074LPST
U1	231094	IC, DEMUX DECODER	18324	N74LS138D
U2	231122	IC, SOIC	01295	SN74LS641-1DW
U3	231123	IC, MULTIPLEXER	18324	74LS151D
U4	231125	IC, DIGITAL, LINE DRIVER	27014	DS26LS31MN
U5	231125	IC, DIGITAL, LINE DRIVER	27014	DS26LS31MN
U6	231122	IC, SOIC	01295	SN74LS641-1DW
U7	230986	IC, 8-BIT COMPARATOR	07263	74F521SC
U8	231092	IC, TRI-STATE BUFFER	18324	74LS244D
U9	231118	IC, DIGITAL BUFFER	01295	SN74LS652DW
U10	231129	IC, OCTAL BUS TRANSCEIVERS	18324	N74LS645-1D
U11	231093	IC, QUAD COMPARATOR	04713	LM339D
U12	231500	IC, 8-INPUT SHIFT REGISTER	18324	N74F299D
U13	231164	IC, MEMORY	21793	231164
U14	231163	IC, MEMORY	21793	231163
U15	230980	IC, DUAL JK POS EDGE-TRIG F-F	07263	74F109SC
U16	231094	IC, DEMUX DECODER	18324	N74LS138D
U17	231092	IC, TRI-STATE BUFFER	18324	74LS244D
U18	230986	IC, 8-BIT COMPARATOR	07263	74F521SC
U19	231162	IC, MEMORY	21793	231162
U20	231124	IC, FLIP-FLOP	18324	N74LS374D
U21	231121	IC, QUADRUPLE 2-INPUT POS-OR GATE	01295	SN74HC32D
U22	231120	IC, 8-BIT, PARALLEL/SERIAL OUT S.R.	18324	74HCT166D
U23	231161	IC, MEMORY	21793	231161
U24	231160	IC, MEMORY	21793	231160
U25	231159	IC, MEMORY	21793	231159
U26	231158	IC, MEMORY	21793	231158
U27	231157	IC, MEMORY	21793	231157

401901-003 PCB ASSY., 1260 MASTER CPU

REF DESIG	RACAL INST P/N	DESCRIPTION	FSC	MANUFACTURER'S P/N
U28	231156	IC, MEMORY	21793	231156
U29	231155	IC, MEMORY	21793	231155
U30	230780	IC, COUNTER TIMER	04713	MC6840P
U31	231136	IC, MICROPROCESSING UNIT	62786	HD68000CP-8
U32	231146	IC, MEMORY, EEPROM	21793	231146
U33	231166	IC, MEMORY	21793	231166
U34	231167	IC, MEMORY	21793	231167
U100	231129	IC, OCTAL BUS TRANSCEIVERS	18324	N74LS645-1D
U101	231118	IC, DIGITAL BUFFER	01295	SN74LS652DW
U102	231092	IC, TRI-STATE BUFFER	18324	74LS244D
U103	230986	IC, 8-BIT COMPARATOR	07263	74F521SC
U104	231127	IC, FLIP-FLOP	04713	SN74LS74AD
U105	231096	IC, QUAD DIFF RECEIVER	01295	AM26LS32ACD
U106	231124	IC, FLIP-FLOP	18324	N74LS374D
U107	231126	IC, NAND GATE	18324	74S38D
U108	231128	IC, ENCODER	01295	SN74LS148D
U109	231124	IC, FLIP-FLOP	18324	N74LS374D
U110	231092	IC, TRI-STATE BUFFER	18324	74LS244D
U111	231093	IC, QUAD COMPARATOR	04713	LM339D
U112	231120	IC, 8-BIT, PARALLEL/SERIAL OUT S.R.	18324	74HCT166D
U113	231094	IC, DEMUX DECODER	18324	N74LS138D
U114	231137	IC, MEMORY	21793	231137
U115	231137	IC, MEMORY	21793	231137
VR1	230951	IC, 1.2V MICRO PWR V REF DIODE	27014	LM385BM-1.2
Z1	080121	RES NETWORK, 3.3K, 16P, 8R	11236	767-163R33KS
Z2	080116	RES NETWORK, 16P8R, 10K	73138	628-AL-103J
Z3	080120	RES NETWORK, 10K	11236	767-161R10K
Z4	080119	RES NETWORK, 220K	91637	SOMC-1603-224K
Z100	080120	RES NETWORK, 10K	11236	767-161R10K
Z101	080120	RES NETWORK, 10K	11236	767-161R10K
Z102	080120	RES NETWORK, 10K	11236	767-161R10K
Z103	080120	RES NETWORK, 10K	11236	767-161R10K
{65}1	411901	PCB OPTION 01 (UNLOADED)	21793	411901
{69}A/R	500022	WIRE, BARE COPPER/TIN, 22 GA	21793	500022
{71}1	601277	IC SOCKET, 28-PIN	06776	ICA-286-S-TG
{76}1	601715	SOCKET, CHIP CARRIER, 68 PIN	09922	Q1LE68P-410T
{77}4	601735-016	CONNECTOR, PCB, RECEPT, 16 PIN	55322	SL116G32
{92}3	610257	STANDOFF, SWAGE, 1/4D, 4-40 X .31	06540	9534BB04403A
{93}1	404782	CABLE ASSY., LED FAIL	21793	404782

1260 Series User Manual

401901-005 PCB ASSY., 1260 MASTER CPU (REV. K)

REF DESIG	RACAL INST P/N	DESCRIPTION	FSC	MANUFACTURER'S P/N
C1	110126	CAP, TANTA, 6.8UF, 35V, 20 PERCENT	05397	T355P685M035A5
C2	110143	CAP, TANTA, 1 UF, 35V, 20 PERCENT	05397	T355A105M035A5
C100-125	R-21-1801	CAP, CHIP, 10 NF	95275	VJ1206Y103MF
C126	R-21-1802	CAP, CHIP, 100 NF	95275	VJ1206Y104MF
C127-128	R-21-1801	CAP, CHIP, 10 NF	95275	VJ1206Y103MF
CR1	211083	DIODE, SILICON	81349	1N916B
P3A	601858-032	CONNECTOR, PCB, PLUG, 32 PIN	52072	CAS32MPF1B
P3B	601858-032	CONNECTOR, PCB, PLUG, 32 PIN	52072	CAS32MPF1B
P3C	601858-032	CONNECTOR, PCB, PLUG, 32 PIN	52072	CAS32MPF1B
P4A	601858-032	CONNECTOR, PCB, PLUG, 32 PIN	52072	CAS32MPF1B
P4B	601858-032	CONNECTOR, PCB, PLUG, 32 PIN	52072	CAS32MPF1B
P4C	601858-032	CONNECTOR, PCB, PLUG, 32 PIN	52072	CAS32MPF1B
P5-6	601710-003	CONNECTOR, RT.ANGLE, SINGLE ROW, 3P	52072	CA-S03R-23B09
Q1	200320	TRANSISTOR, NPN	04713	MMBT3904
Q2	200295	TRANSISTOR, N-CHAN, MOSFET	17856	1VN10KM
Q3	200320	TRANSISTOR, NPN	04713	MMBT3904
Q4	200320	TRANSISTOR, NPN	04713	MMBT3904
Q100	200320	TRANSISTOR, NPN	04713	MMBT3904
R100	050000-102	RES, CHIP, 1K, .06W, 5 PCT	91637	CRCW-0805SERIES
R101	050038	RES, CHIP, 825 OHM, 1/8W, 5 PCT	65940	MCR18825J
R102	R-20-5766	RES, CHIP, 2.7K, 1/8W, 5 PCT	65940	MCR18-2.7K OHM-5 PCT
R103	050000-102	RES, CHIP, 1K, .06W, 5 PCT	91637	CRCW-0805SERIES
R104	R-20-5764	RES, CHIP, 100 OHM, 1/8W, 5 PCT	65940	MCR18-100 OHM-5 PCT
R105	050040	RES, CHIP, 6.04K, 1/8W, 1 PCT	65940	MCR18-6.04KFW
R106	050000-102	RES, CHIP, 1K, .06W, 5 PCT	91637	CRCW-0805SERIES
R107	050047	RES, CHIP, 2.21K, .06W, 1 PCT	56235	50705CPX2211F30
R108	R-20-5787	RES, CHIP, 330 OHM, 1/8W, 5 PCT, 200V	65940	MCR18-330 OHM-5 PCT
R109	R-20-5792	RES, CHIP, 1K, 1/8W, 5 PCT, 200V	65940	MCR18-1K-5 PCT
R110	R-20-5792	RES, CHIP, 1K, 1/8W, 5 PCT, 200V	65940	MCR18-1K-5 PCT
R111	R-20-5765	RES, CHIP, 470 OHM, 1/8W, 5 PCT	65940	MCR18-470 OHM-5 PCT
R112	R-20-5792	RES, CHIP, 1K, 1/8W, 5 PCT, 200V	65940	MCR18-1K-5 PCT
S1	601699	SWITCH, DIP, 8 POS, LOW PROFILE	71450	207-8-LPST
S2	601859	SWITCH, DIP, 4 POS	11237	2074LPST
U1	231094	IC, DEMUX DECODER	18324	N74LS138D
U2	231122	IC, SOIC	01295	SN74LS641-1DW
U3	231123	IC, MULTIPLEXER	18324	74LS151D
U4-5	231125	IC, DIGITAL, LINE DRIVER	27014	DS26LS31MN
U6	231122	IC, SOIC	01295	SN74LS641-1DW
U7	230986	IC, 8-BIT COMPARATOR	07263	74F521SC
U8	231092	IC, TRI-STATE BUFFER	18324	74LS244D
U9	231118	IC, DIGITAL BUFFER	01295	SN74LS652DW
U10	231129	IC, OCTAL BUS TRANSCEIVERS	18324	N74LS645-1D
U11	231093	IC, QUAD COMPARATOR	04713	LM339D
U12	231500	IC, INPUT SHIFT REGISTER	18324	N74F299D
U13	231164	IC, MEMORY	21793	231164
U14	231163	IC, MEMORY	21793	231163
U15	230980	IC, DUAL JK POS EDGE-TRIG F-F	07263	74F109SC
U16	231094	IC, DEMUX DECODER	18324	N74LS138D
U17	231092	IC, TRI-STATE BUFFER	18324	74LS244D
U18	230986	IC, 8-BIT COMPARATOR	07263	74F521SC
U19	231162	IC, MEMORY	21793	231162
U20	231124	IC, FLIP-FLOP	18324	N74LS374D
U21	231121	IC, QUADRUPLE 2-INPUT POS-OR GATE	01295	SN74HC32D
U22	231120	IC, 8-BIT, PARALLEL/SERIAL OUT S.R.	18324	74HCT166D
U23	231161	IC, MEMORY	21793	231161
U24	231408-001	IC, DIGITAL, 16L80, PAL	21793	231408-001
U25	231408-003	IC, DIGITAL, 22V10H, PAL	21793	231408-003
U26	231158	IC, MEMORY	21793	231158
U27	231408-004	IC, DIGITAL, 22V10H, PAL	21793	231408-004
U28	231156	IC, MEMORY	21793	231156

401901-005 PCB ASSY., 1260 MASTER CPUB (REV. K)

REF DESIG	RACAL INST P/N	DESCRIPTION	FSC	MANUFACTURER'S P/N
U29	1231408-002	IC, DIGITAL, 30RA10, PAL	21793	1231408-002
U30	1230780	IC, COUNTER TIMER	04713	1MC6840P
U31	1231136	IC, MICROPROCESSING UNIT	62786	1HD68000CP-8
U32	1231440	IC, MEMORY, PLCC	21793	1231440
U33	1231417-001	IC, MEMORY EPROM	21793	1231417-001
U34	1231417-002	IC, MEMORY EPROM	21793	1231417-002
U100	1231129	IC, OCTAL BUS TRANSCEIVERS	18324	1N74LS645-1D
U101	1231118	IC, DIGITAL BUFFER	01295	1SN74LS652DW
U102	1231092	IC, TRI-STATE BUFFER	18324	174LS244D
U103	1230986	IC, 8-BIT COMPARATOR	07263	174F521SC
U104	1231127	IC, FLIP-FLOP	04713	1SN74LS74AD
U105	1231096	IC, QUAD DIFF RECEIVER	01295	1AM26LS32ACD
U106	1231124	IC, FLIP-FLOP	18324	1N74LS374D
U107	1231126	IC, NAND GATE	18324	174S38D
U108	1231128	IC, ENCODER	01295	1SN74LS148D
U109	1231124	IC, FLIP-FLOP	18324	1N74LS374D
U110	1231092	IC, TRI-STATE BUFFER	18324	174LS244D
U111	1231093	IC, QUAD COMPARATOR	04713	1LM339D
U112	1231120	IC, 8-BIT, PARALLEL/SERIAL OUT S.R.	18324	174HCT166D
U113	1231094	IC, DEMUX DECODER	18324	1N74LS138D
U114-115	1231137	IC, MEMORY	21793	1231137
VR1	1230951	IC, 1.2V MICRO PWR V REF DIODE	27014	1LM385BM-1.2
Z1	1080121	RES NETWORK, 3.3K, 16P8R	11236	1767-163R33KS
Z2	1080116	RES NETWORK, 16P8R, 10K	73138	1628-AL-103J
Z3	1080120	RES NETWORK, 10K, 16P15R	11236	1767-161R10K
Z4	1080119	RES NETWORK, 220K, 16P8R	91637	1SOMC-1603-224K
Z100-Z103	1080120	RES NETWORK, 10K, 16P15R	11236	1767-161R10K
{65}1	1411901-005	PCB OPTION 01 (UNLOADED)	21793	1411901-005
{69}A/R	1500022	WIRE, BARE COPPER/TIN, 22 GA	21793	1500022
{71}1	1601277	IC SOCKET, 28-PIN	06776	1ICA-286-S-TG
{76}1	1602068-068	CONNECTOR RECEPTACLE 68 PIN	55322	1PLCC-68-T-A
{77}4	1601735-016	CONNECTOR, PCB, RECEPT, 16 PIN	55322	1SL116G32
{80}3	1615541	SCREW, PFH, 4-40X.250	-	-
{92}3	1610257	STANDOFF, SWAGE, 1/4D, 4-40 X .31	06540	19534BB04403A
{93}1	1404782	CABLE ASSY., LED FAIL	21793	1404782
{95}1	1921423	LABEL, CE MARKING	21793	1921423

List of Suppliers

FSC	SUPPLIER	FSC	SUPPLIER
00779	AMP, INC. HARRISBURG, PA	18324	SIGNETICS, INC. SUNNYVALE, CA
01295	TEXAS INSTRUMENTS, INC. DALLAS, TX	21793	RACAL INSTRUMENTS INC. IRVINE, CA
01526	GENICOM CORP. WAYNESBORO, VA	22526	DUPONT CONNECTOR CO. NEW CUMBERLAND, PA
02735	RCA (SOLID STATE DIV.) SOMERVILLE, NJ	27014	NATIONAL SEMI-CONDUCTOR CORP. SANTA CLARA, CA
03508	GENERAL ELECTRIC CO. (SEMICONDUCTOR PRODUCTS) AUBURN, NY	29005	STORM PRODUCTS CO. LOS ANGELES, CA
04713	MOTOROLA, INC. (SEMICONDUCTOR PRODUCTS DIV.) PHOENIX, AZ	51506	ACCURATE SCREW MACHINE NUTLEY, NJ
04946	STANDARD WIRE & CABLE RANCHO DOMINGUEZ, CA	52072	CIRCUIT ASSY. CORP. COSTA MESA, CA
05397	UNION CARBIDE CORP. (MATERIALS SYSTEMS DIV.) CLEVELAND, OH	52210	GETTING ENGRG. & MFG. CO. SPRING MILLS, PA
05972	LOCTITE CORP. HARTFORD, CT	53387	THREE M (3M) CO. ST. PAUL, MN
06383	PANDUIT CORP. TINLEY PARK, IL	55322	SAMTEC, INC NEW ALBANY, IN
06540	AMATOM ELECTRONIC HARDWARE NEW ROCHELLE, NY	56235	PRECISION STDS CORP. (BIRTCHEM SEMI-CONDUCTOR DIV.) SANTA ANA, CA
06776	ROBINSON NUGENT INC. NEW ALBANY, IN	56289	SPAGUE ELECTRIC CO. N. ADAMS, MA
07263	FAIRCHILD (SEMICONDUCTOR DIV.) MOUNTAIN VIEW, CA	61529	AROMAT CORP. CUPERTINO, CA
08261	SPECTRA-STRIP CORP. GARDEN GROVE, CA	62559	SCHROFF, INC. WARWICK, RI
09922	BURNDY CORPORATION NORWALK, CT	62786	HITACHI AMERICA LTD. SAN JOSE, CA
11236	CTS OF BERNE, INC. BERNE, IN	65832	AMERICAN RESEARCH & ENGINEERING ELGIN, IL
11237	CTS KEENE INC. PASO ROBLES, CA	65940	ROHM CORP. IRVINE, CA
16956	DENNISON MFG. CO. FRAMINGTON, MA	67349	PHILLIPS COMPONENTS INC. LAGUNA HILLS, CA
17856	SILICONIX, INC. SANTA CLARA, CA	70903	BELDEN CORP. CHICAGO, IL
		71400	MCGRAW-EDISON CO. (BUSSMAN DIV.) ST. LOUIS, MO

List of Suppliers continued

FSC	SUPPLIER	
71450	CTS CORP.	
	ELKHART, IN	
73138	BECKMAN INSTRUMENTS	
	FULLERTON, CA	
73445	AMPEREX ELECTRONIC CORP.	
	HICKSVILLE, NY	
75915	LITTELFUSE, INC.	
	DES PLAINES, IL	
78189	ILLINOIS TOOL WORKS, INC.	
	(SHAKEPROOF DIV.)	
	ELGIN, IL	
81349	MILITARY SPECIFICATION	
83330	HERMAN H. SMITH, INC.	
	BROOKLYN, NY	
86928	SEASTROM MFG. CO.	
	GLENDALE, CA	
88245	LITTON PRECISION PRODUCTS	
	VAN NUYS, CA	
91637	DALE ELECTRONICS, INC.	
	COLUMBUS, NE	
92194	ALPHA WIRE	
	ELIZABETH, NJ	
95275	VITRAMON, INC.	
	BRIDGEPORT, CT	
98291	SEAELECTRO CORP.	
	MAMARONECK, NY	
ALMSI	ALLEGRO MICRO SYSTEM INC.	
	(FMC:OCVK3)	
	WORCHESTER, MA	

Chapter 7

PRODUCT SUPPORT

Product Support

Racal Instruments has a complete Service and Parts Department. If you need technical assistance or should it be necessary to return your product for repair or calibration, call 1-800-722-3262. If parts are required to repair the product at your facility, call 1-949-859-8999 and ask for the Parts Department.

When sending your instrument in for repair, complete the form in the back of this manual.

For worldwide support and the office closes to your facility, refer to the Support Offices section on the following page.

Reshipment Instructions

Use the original packing material when returning the 1260 to Racal Instruments for calibration or servicing. The original shipping crate and associated packaging material will provide the necessary protection for safe reshipment.

If the original packing material is unavailable, contact Racal Instruments Customer Service for information.

Support Offices

Racal Instruments, Inc.

4 Goodyear St., Irvine, CA 92618-2002
Tel: (800) RACAL-ATE, (800) 722-2528,
(949) 859-8999; FAX: (949) 859-7139

Racal Instruments, Ltd.

480 Bath Road, Slough, Berkshire, SL1 6BE, United Kingdom
Tel: +44 (0) 1628 604455; FAX: +44 (0) 1628 662017

Racal Systems Electronique S.A.

18 Avenue Dutartre, 78150 LeChesnay, France
Tel: +33 (1) 3923 2222; FAX: +33 (1) 3923 2225

Racal Systems Elettronica s.r.l.

Strada 2-Palazzo C4, 20090 Milanofiori Assago, Milan, Italy
Tel: +39 (0)2 5750 1796; FAX +39 (0)2 5750 1828

Racal Elektronik System GmbH.

Technologiepark Bergisch Gladbach, Friedrich-Ebert-Strasse,
D-51429 Bergisch Gladbach, Germany
Tel.: +49 2204 8442 00; FAX: +49 2204 8442 19

Racal Instruments, Ltd.

Unit 5, 25F., Mega Trade Center, No 1, Mei Wan Road, Tsuen
Wan, Hong Kong, PRC
Tel: +852 2405 5500, FAX: +852 2416 4335

REPAIR AND CALIBRATION REQUEST FORM

To allow us to better understand your repair requests, we suggest you use the following outline when calling and include a copy with your instrument to be sent to the Racal Repair Facility.

Model _____ Serial No. _____ Date _____

Company Name _____ Purchase Order # _____

Billing Address _____

City

State/Province

Zip/Postal Code

Country

Shipping Address _____

City

State/Province

Zip/Postal Code

Country

Technical Contact _____ Phone Number () _____

Purchasing Contact _____ Phone Number () _____

1. Describe, in detail, the problem and symptoms you are having. Please include all set up details, such as input/output levels, frequencies, waveform details, etc.

2. If problem is occurring when unit is in remote, please list the program strings used and the controller type.

3. Please give any additional information you feel would be beneficial in facilitating a faster repair time (i.e., modifications, etc.)

4. Is calibration data required? Yes No (please circle one)

Call before shipping
Note: We do not accept
"collect" shipments.

Ship instruments to nearest support office
listed on back.